

November 30, 2022
Revised January 5, 2023

Mr. Jonathan Ferbrache
Professional Landscape Architect and Resource Specialist
Fairfield Soil and Water Conservation District
831 College Avenue, Suite B
Lancaster, Ohio 43130

Re: Denison University Solar Field Sites – Soil Investigation Activities. 15929.0003.

Dear Mr. Ferbrache:

Verdantas LLC (Verdantas) prepared this report to summarize the investigation methods and findings of the soil investigation at three sites (Site 1 – East of Creek, Site 2 – East of Creek, and Site 3 – West of Creek) located in Granville, Ohio as shown on Figure 1. All three sites are on property owned by Denison University and are currently used as an active photovoltaic (solar) electric generation facility. Denison University has contracted with an outside energy partner to build, maintain, and operate the three solar sites. Verdantas has been retained by Fairfield Soil and Water Conservation District, Fairfield County, Ohio (Client) to perform select soil tests including bulk density and moisture tests, water infiltration tests, and soil compaction/probing tests. The soil investigation was performed on November 8, 2022 (soil bulk density and moisture tests, water infiltration tests, and soil compaction/probing tests) and November 9, 2022 (remaining water infiltration test). The former use of the investigation sites was provided to Verdantas by the Client and is as follows:

- **Site 1** is a cut site. It was a former farm field through the mid 1980's. Topsoil was stripped from much of the area in the late 1980's and reverted to scrub shrub until converted to the solar array in 2017. The site was planted into pollinator plant species in spring of 2018.
- **Site 2** was generally in situ former farm field through the mid 1980's and reverted to scrub shrub until converted to the solar array in 2017. The site was planted into pollinator plant species in spring of 2018.
- **Site 3** is a fill site. In the early 2000's, it was converted to turf athletic field (around 2006) and was converted to the solar array in 2017. The site remains in turf grass.

The soil types and soil characteristics at the investigation sites were evaluated using the United States Department of Agriculture's (USDA's) online interactive soil data source Web Soil Survey and are presented in Attachment 1. One Web Soil Survey covers the general area of all three investigative sites, and the second Web Soil Survey focuses on each of the three investigative sites.

Based on the historical weather data obtained from online website Wunderground.com, within 30 days prior to the investigation, precipitation events occurred on October 13 (0.17 inch), October 19 (0.18 inch), October 20 (0.01 inch), October 27 (0.03 inch), October 31 (0.18 inch) and November 1 (0.03 inch).

SOIL TESTS AND INVESTIGATION METHODS

At each site, Verdantas performed the following tests: one (1) soil bulk density and moisture test, one (1) soil infiltration test, and 11 soil compaction/probing tests.

Soil Bulk Density and Moisture Tests

Soil bulk density and moisture tests were performed using a Nuclear Moisture Density device (Nuclear Gauge) which is specifically designed to measure the moisture and density of soils. The soil bulk density tests were performed by Verdantas' field technician, who is trained and licensed to operate the Nuclear Gauge device. Tests were performed in accordance with the ASTM D6938 method (Attachment 2). Prior to positioning the Nuclear Gauge on the test location and per Client's request, the test was performed on the native soil underlying the loose topsoil and organic material.

Water Infiltration Tests

Water infiltration tests were performed using a double ring infiltrometer in accordance with the ASTM D3385 method (Attachment 2). Double ring infiltrometer consisted of two stainless steel rings measuring 12 inches and 24 inches in diameter, both being 20 inches high, and just over 1/16 inches thick. Upon completion of the soil bulk density and moisture tests, the water infiltration tests were performed at the very same testing location. The test consisted of measuring the potential water loss (infiltration into the subsurface) from the inner ring over a period and maintaining the constant water level (head) in both rings. Prior to measuring the water loss in regular time intervals, water was poured into both rings and left 30 minutes to pre-soak the soil.

Soil Compaction / Probing Tests

The tests were performed using a Soil Compaction Tester consisting of a 24-inch-long stainless steel rod with a ground-penetrating sharpened cone on one end, and a dial gauge on the other end. The rod is pushed into the ground in three-inch increments and the resistance of the cone in pounds per square inch (PSI) is displayed and observed on the dial as it is pushed into the ground.

SOIL TEST AND INVESTIGATION RESULTS

Soil Bulk Density and Moisture Tests

The test locations for each site are shown on Figures 2 through 4. Prior to the tests, approximately 1 inch, 0.5 inch, and 2.5 inches of loose topsoil were removed from testing locations at Site 1- East of Creek, Site 2 - East of Creek, and Site 3 – West of Creek, respectively, and the soil surface was prepared (flattened using a hoe and spatula) for the tests. Test results from all three sites are shown in Table 1. The soil bulk density was calculated using a formula:

$$BD = DD \times (1+W)$$

where:

BD is Bulk (wet) Density expressed in pounds per cubic foot (pcf),
DD is Dry Density expressed in pounds per cubic foot (pcf), and
W is soil moisture content expressed as a percentage moisture (%)

Table 1: Soil Bulk Density at investigation sites

| | Site 1 – East of Creek | Site 2 – East of Creek | Site 3 – East of Creek |
|-----------------|------------------------|------------------------|------------------------|
| DD (pcf) | 102.8 | 99.0 | 99.9 |
| W (%) | 18.2 (0.182) | 16.9 (0.169) | 25.1 (0.251) |
| BD (pcf) | 121.51 | 115.73 | 124.97 |

Verdantas field staff sampled and logged the top six inches of the soil adjacent to the test locations at all three sites and described soil as predominantly clayey soil with up to 20% of medium-grained sand present (Sites 1 and 2 – East of Creek) and clayey soil with trace sand (Site 3 – West of Creek).

Water Infiltration Tests

The test locations for each site are shown on Figures 2 through 4. Upon completion of soil bulk density tests, water infiltration tests were performed at the very same testing location in order to facilitate any future comparison of the test results. Field forms with observed water infiltration measurements are included as Attachment 3.

At Site 1 – East of Creek, initial observed water drop per 30-minute time interval was 0.5 inches. However, the water infiltration decreased gradually and completely ceased after 2 hours since the commencement of the test. This suggests that:

- The initial and slow water infiltration could be contributed to water filling the soil pores in the vadose zone, and
- Once the clay-size pores were filled with water, the capillary forces acting on the pore water substantially retarded further water percolation indicating low permeability soil.

At Site 2 – East of Creek, after initial drop of 0.5 inches per 30-minute period, the water infiltration rate stabilized at 1.0 inch per hour.

At Site 3 – West of Creek, after initial observed water drop of 0.25 inches per 30-minute pre-soaking time interval, there was no water drop/water infiltration detected for the next 2-hour period indicating low permeability soil similar to Site 1 - East of Creek.

It should be emphasized that these water infiltration test results represent hydrological conditions only at the point of testing (spatially limited area) and caution should be exercised for any extrapolation or the application of the hydrological conditions to the whole site.

Soil Compaction / Probing Tests

The test locations for each site are shown on Figures 2 through 4. A total of 11 locations at each site were tested and the tabulated results are presented in Tables 2 through 4. All measurements started below the loose layer of topsoil.

Table 2: Soil Compaction / Probing Test Results at Site 1 - East of Creek

| SITE 1 - EAST OF CREEK | | | | | | |
|------------------------|--|---------|---------|----------|-----------|-------|
| Location | Soil Probing Resistance Across Depth (PSI) | | | | | |
| | 0" - 3" | 3" - 6" | 6" - 9" | 9" - 12" | 12" - 18" | > 18" |
| 1 | 200 | 300 | NA | NA | NA | NA |
| 2 | 200 | 300 | 300 | 300 | 300 | NA |
| 3 | 300 | 300 | 300 | 300 | 300 | NA |
| 4 | 300 | 300 | 300 | 300 | NA | NA |
| 5 | 200 | 200 | 300 | 300 | 300 | NA |
| 6 | 200 | 300 | 300 | 300 | 300 | NA |
| 7 | 300 | 300 | 300 | NA | NA | NA |
| 8 | 200 | 200 | 300 | 300 | 300 | NA |
| 9 | 200 | 300 | 300 | 300 | 300 | NA |
| 10 | 300 | 300 | 300 | 300 | 300 | NA |
| 11 | 300 | 300 | 300 | 300 | NA | NA |

NA - Soil probing resistance exceeded instrument range

Table 3: Soil Compaction / Probing Test Results at Site 2 - East of Creek

| SITE 2 - EAST OF CREEK | | | | | | |
|------------------------|------------------------------------|---------|---------|----------|-----------|-------|
| Location | Soil Resistance Across Depth (PSI) | | | | | |
| | 0" - 3" | 3" - 6" | 6" - 9" | 9" - 12" | 12" - 18" | > 18" |
| 1 | 300 | 300 | 300 | 300 | 300 | NA |
| 2 | 300 | 300 | 300 | 300 | 300 | NA |
| 3 | 300 | 300 | 300 | 300 | NA | NA |
| 4 | 200 | 300 | 300 | 300 | 300 | NA |
| 5 | 300 | 300 | 300 | 300 | NA | NA |
| 6 | 300 | 300 | 300 | 300 | 300 | NA |
| 7 | 300 | 300 | 300 | 300 | 300 | NA |
| 8 | 300 | 300 | 300 | 300 | 300 | NA |
| 9 | 200 | 300 | 300 | 300 | 300 | NA |
| 10 | 300 | 300 | 300 | 300 | 300 | NA |
| 11 | 300 | 300 | 300 | 300 | 300 | NA |

NA - Soil probing resistance exceeded instrument range

Table 4: Soil Compaction / Probing Test Results at Site 3 - West of Creek

| SITE 3 - WEST OF CREEK | | | | |
|------------------------|------------------------------------|---------|---------|------|
| Location | Soil Resistance Across Depth (PSI) | | | |
| | 0" - 3" | 3" - 6" | 6" - 9" | > 9" |
| 1 | 100 | 200 | 300 | NA |
| 2 | 100 | 200 | 300 | NA |
| 3 | 100 | 200 | 300 | NA |
| 4 | 100 | 200 | 300 | NA |
| 5 | 100 | 200 | 300 | NA |
| 6 | 100 | 200 | 300 | NA |
| 7 | 200 | 300 | NA | NA |
| 8 | 200 | 300 | NA | NA |
| 9 | 200 | 300 | NA | NA |
| 10 | 200 | 300 | NA | NA |
| 11 | 300 | NA | NA | NA |

NA - Soil probing resistance exceeded instrument range

As can be seen from Tables 2 and 3 the maximum depth to which the probe could be pushed without damaging the tip was 18 inches. All three tables also indicate relatively compacted soil potentially restrictive for root growth within the top 6 inches. The maximum depth to which the soil resistance could be measured at the Site 3 – West of Creek was only 9 inches.

Please feel free to contact me at (412) 213-8044 should you have any questions or comments.

Sincerely,
Verdantas



Alex Prvanovic,
Senior Hydrogeologist, PhD, PG

ct: Mark J. Bonifas, PE, Verdantas
Attachments

ATTACHMENT 1

Custom Soil Resource Reports for Licking County, Ohio



United States
Department of
Agriculture

NRCS

Natural
Resources
Conservation
Service

A product of the National
Cooperative Soil Survey,
a joint effort of the United
States Department of
Agriculture and other
Federal agencies, State
agencies including the
Agricultural Experiment
Stations, and local
participants

Custom Soil Resource Report for **Licking County, Ohio**



Preface

Soil surveys contain information that affects land use planning in survey areas. They highlight soil limitations that affect various land uses and provide information about the properties of the soils in the survey areas. Soil surveys are designed for many different users, including farmers, ranchers, foresters, agronomists, urban planners, community officials, engineers, developers, builders, and home buyers. Also, conservationists, teachers, students, and specialists in recreation, waste disposal, and pollution control can use the surveys to help them understand, protect, or enhance the environment.

Various land use regulations of Federal, State, and local governments may impose special restrictions on land use or land treatment. Soil surveys identify soil properties that are used in making various land use or land treatment decisions. The information is intended to help the land users identify and reduce the effects of soil limitations on various land uses. The landowner or user is responsible for identifying and complying with existing laws and regulations.

Although soil survey information can be used for general farm, local, and wider area planning, onsite investigation is needed to supplement this information in some cases. Examples include soil quality assessments (<http://www.nrcs.usda.gov/wps/portal/nrcs/main/soils/health/>) and certain conservation and engineering applications. For more detailed information, contact your local USDA Service Center (<https://offices.sc.egov.usda.gov/locator/app?agency=nrcs>) or your NRCS State Soil Scientist (http://www.nrcs.usda.gov/wps/portal/nrcs/detail/soils/contactus/?cid=nrcs142p2_053951).

Great differences in soil properties can occur within short distances. Some soils are seasonally wet or subject to flooding. Some are too unstable to be used as a foundation for buildings or roads. Clayey or wet soils are poorly suited to use as septic tank absorption fields. A high water table makes a soil poorly suited to basements or underground installations.

The National Cooperative Soil Survey is a joint effort of the United States Department of Agriculture and other Federal agencies, State agencies including the Agricultural Experiment Stations, and local agencies. The Natural Resources Conservation Service (NRCS) has leadership for the Federal part of the National Cooperative Soil Survey.

Information about soils is updated periodically. Updated information is available through the NRCS Web Soil Survey, the site for official soil survey information.

The U.S. Department of Agriculture (USDA) prohibits discrimination in all its programs and activities on the basis of race, color, national origin, age, disability, and where applicable, sex, marital status, familial status, parental status, religion, sexual orientation, genetic information, political beliefs, reprisal, or because all or a part of an individual's income is derived from any public assistance program. (Not all prohibited bases apply to all programs.) Persons with disabilities who require

alternative means for communication of program information (Braille, large print, audiotape, etc.) should contact USDA's TARGET Center at (202) 720-2600 (voice and TDD). To file a complaint of discrimination, write to USDA, Director, Office of Civil Rights, 1400 Independence Avenue, S.W., Washington, D.C. 20250-9410 or call (800) 795-3272 (voice) or (202) 720-6382 (TDD). USDA is an equal opportunity provider and employer.

Contents

| | |
|--|----|
| Preface | 2 |
| How Soil Surveys Are Made | 5 |
| Soil Map | 8 |
| Soil Map..... | 9 |
| Legend..... | 10 |
| Map Unit Legend..... | 11 |
| Map Unit Descriptions..... | 12 |
| Licking County, Ohio..... | 14 |
| AmB2—Amanda silt loam, 2 to 6 percent slopes, eroded..... | 14 |
| AmC2—Amanda silt loam, 6 to 12 percent slopes, eroded..... | 15 |
| AmD2—Amanda silt loam, 12 to 18 percent slopes, eroded..... | 16 |
| BrD—Brownsville channery silt loam, 12 to 18 percent slopes..... | 17 |
| BrE—Brownsville channery silt loam, 18 to 25 percent slopes..... | 18 |
| BrF—Brownsville channery silt loam, 25 to 35 percent slopes..... | 19 |
| Cen1B1—Centerburg silt loam, 2 to 6 percent slopes..... | 21 |
| Cen1C2—Centerburg silt loam, 6 to 12 percent slopes, eroded..... | 23 |
| GfA—Glenford silt loam, 0 to 2 percent slopes..... | 25 |
| GfB—Glenford silt loam, 2 to 6 percent slopes..... | 26 |
| Lu—Luray silty clay loam..... | 27 |
| McC2—Mechanicsburg silt loam, 6 to 12 percent slopes, eroded..... | 28 |
| McD2—Mechanicsburg silt loam, 12 to 18 percent slopes, eroded..... | 29 |
| OcA—Ockley silt loam, Southern Ohio Till Plain, 0 to 2 percent slopes..... | 30 |
| OcB—Ockley silt loam, Southern Ohio Till Plain, 2 to 6 percent slopes..... | 32 |
| OcC2—Ockley silt loam, 6 to 12 percent slopes, eroded..... | 33 |
| Sh—Shoals silt loam, 0 to 2 percent slopes, occasionally flooded..... | 34 |
| W—Water..... | 36 |
| References | 37 |

How Soil Surveys Are Made

Soil surveys are made to provide information about the soils and miscellaneous areas in a specific area. They include a description of the soils and miscellaneous areas and their location on the landscape and tables that show soil properties and limitations affecting various uses. Soil scientists observed the steepness, length, and shape of the slopes; the general pattern of drainage; the kinds of crops and native plants; and the kinds of bedrock. They observed and described many soil profiles. A soil profile is the sequence of natural layers, or horizons, in a soil. The profile extends from the surface down into the unconsolidated material in which the soil formed or from the surface down to bedrock. The unconsolidated material is devoid of roots and other living organisms and has not been changed by other biological activity.

Currently, soils are mapped according to the boundaries of major land resource areas (MLRAs). MLRAs are geographically associated land resource units that share common characteristics related to physiography, geology, climate, water resources, soils, biological resources, and land uses (USDA, 2006). Soil survey areas typically consist of parts of one or more MLRA.

The soils and miscellaneous areas in a survey area occur in an orderly pattern that is related to the geology, landforms, relief, climate, and natural vegetation of the area. Each kind of soil and miscellaneous area is associated with a particular kind of landform or with a segment of the landform. By observing the soils and miscellaneous areas in the survey area and relating their position to specific segments of the landform, a soil scientist develops a concept, or model, of how they were formed. Thus, during mapping, this model enables the soil scientist to predict with a considerable degree of accuracy the kind of soil or miscellaneous area at a specific location on the landscape.

Commonly, individual soils on the landscape merge into one another as their characteristics gradually change. To construct an accurate soil map, however, soil scientists must determine the boundaries between the soils. They can observe only a limited number of soil profiles. Nevertheless, these observations, supplemented by an understanding of the soil-vegetation-landscape relationship, are sufficient to verify predictions of the kinds of soil in an area and to determine the boundaries.

Soil scientists recorded the characteristics of the soil profiles that they studied. They noted soil color, texture, size and shape of soil aggregates, kind and amount of rock fragments, distribution of plant roots, reaction, and other features that enable them to identify soils. After describing the soils in the survey area and determining their properties, the soil scientists assigned the soils to taxonomic classes (units). Taxonomic classes are concepts. Each taxonomic class has a set of soil characteristics with precisely defined limits. The classes are used as a basis for comparison to classify soils systematically. Soil taxonomy, the system of taxonomic classification used in the United States, is based mainly on the kind and character of soil properties and the arrangement of horizons within the profile. After the soil

Custom Soil Resource Report

scientists classified and named the soils in the survey area, they compared the individual soils with similar soils in the same taxonomic class in other areas so that they could confirm data and assemble additional data based on experience and research.

The objective of soil mapping is not to delineate pure map unit components; the objective is to separate the landscape into landforms or landform segments that have similar use and management requirements. Each map unit is defined by a unique combination of soil components and/or miscellaneous areas in predictable proportions. Some components may be highly contrasting to the other components of the map unit. The presence of minor components in a map unit in no way diminishes the usefulness or accuracy of the data. The delineation of such landforms and landform segments on the map provides sufficient information for the development of resource plans. If intensive use of small areas is planned, onsite investigation is needed to define and locate the soils and miscellaneous areas.

Soil scientists make many field observations in the process of producing a soil map. The frequency of observation is dependent upon several factors, including scale of mapping, intensity of mapping, design of map units, complexity of the landscape, and experience of the soil scientist. Observations are made to test and refine the soil-landscape model and predictions and to verify the classification of the soils at specific locations. Once the soil-landscape model is refined, a significantly smaller number of measurements of individual soil properties are made and recorded. These measurements may include field measurements, such as those for color, depth to bedrock, and texture, and laboratory measurements, such as those for content of sand, silt, clay, salt, and other components. Properties of each soil typically vary from one point to another across the landscape.

Observations for map unit components are aggregated to develop ranges of characteristics for the components. The aggregated values are presented. Direct measurements do not exist for every property presented for every map unit component. Values for some properties are estimated from combinations of other properties.

While a soil survey is in progress, samples of some of the soils in the area generally are collected for laboratory analyses and for engineering tests. Soil scientists interpret the data from these analyses and tests as well as the field-observed characteristics and the soil properties to determine the expected behavior of the soils under different uses. Interpretations for all of the soils are field tested through observation of the soils in different uses and under different levels of management. Some interpretations are modified to fit local conditions, and some new interpretations are developed to meet local needs. Data are assembled from other sources, such as research information, production records, and field experience of specialists. For example, data on crop yields under defined levels of management are assembled from farm records and from field or plot experiments on the same kinds of soil.

Predictions about soil behavior are based not only on soil properties but also on such variables as climate and biological activity. Soil conditions are predictable over long periods of time, but they are not predictable from year to year. For example, soil scientists can predict with a fairly high degree of accuracy that a given soil will have a high water table within certain depths in most years, but they cannot predict that a high water table will always be at a specific level in the soil on a specific date.

After soil scientists located and identified the significant natural bodies of soil in the survey area, they drew the boundaries of these bodies on aerial photographs and

Custom Soil Resource Report

identified each as a specific map unit. Aerial photographs show trees, buildings, fields, roads, and rivers, all of which help in locating boundaries accurately.

Soil Map

The soil map section includes the soil map for the defined area of interest, a list of soil map units on the map and extent of each map unit, and cartographic symbols displayed on the map. Also presented are various metadata about data used to produce the map, and a description of each soil map unit.

Custom Soil Resource Report Soil Map



Map Scale: 1:7,700 if printed on A landscape (11" x 8.5") sheet.

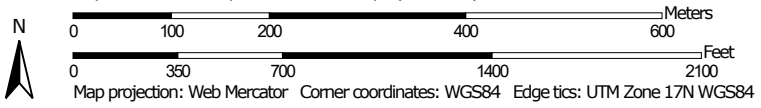

MAP LEGEND

Area of Interest (AOI)

 Area of Interest (AOI)

Soils

 Soil Map Unit Polygons

 Soil Map Unit Lines

 Soil Map Unit Points

Special Point Features

 Blowout

 Borrow Pit

 Clay Spot

 Closed Depression

 Gravel Pit

 Gravelly Spot

 Landfill

 Lava Flow

 Marsh or swamp

 Mine or Quarry

 Miscellaneous Water

 Perennial Water

 Rock Outcrop

 Saline Spot

 Sandy Spot

 Severely Eroded Spot

 Sinkhole

 Slide or Slip

 Sodic Spot

 Spoil Area

 Stony Spot

 Very Stony Spot

 Wet Spot

 Other

 Special Line Features

Water Features

 Streams and Canals

Transportation

 Rails

 Interstate Highways

 US Routes

 Major Roads

 Local Roads

Background

 Aerial Photography

MAP INFORMATION

The soil surveys that comprise your AOI were mapped at 1:15,800.

Warning: Soil Map may not be valid at this scale.

Enlargement of maps beyond the scale of mapping can cause misunderstanding of the detail of mapping and accuracy of soil line placement. The maps do not show the small areas of contrasting soils that could have been shown at a more detailed scale.

Please rely on the bar scale on each map sheet for map measurements.

Source of Map: Natural Resources Conservation Service
 Web Soil Survey URL:
 Coordinate System: Web Mercator (EPSG:3857)

Maps from the Web Soil Survey are based on the Web Mercator projection, which preserves direction and shape but distorts distance and area. A projection that preserves area, such as the Albers equal-area conic projection, should be used if more accurate calculations of distance or area are required.

This product is generated from the USDA-NRCS certified data as of the version date(s) listed below.

Soil Survey Area: Licking County, Ohio
 Survey Area Data: Version 20, Sep 9, 2022

Soil map units are labeled (as space allows) for map scales 1:50,000 or larger.

Date(s) aerial images were photographed: Apr 1, 2020—Oct 1, 2020

The orthophoto or other base map on which the soil lines were compiled and digitized probably differs from the background imagery displayed on these maps. As a result, some minor shifting of map unit boundaries may be evident.

Map Unit Legend

| Map Unit Symbol | Map Unit Name | Acres in AOI | Percent of AOI |
|------------------------------------|---|--------------|----------------|
| AmB2 | Amanda silt loam, 2 to 6 percent slopes, eroded | 1.5 | 0.5% |
| AmC2 | Amanda silt loam, 6 to 12 percent slopes, eroded | 22.3 | 7.6% |
| AmD2 | Amanda silt loam, 12 to 18 percent slopes, eroded | 0.8 | 0.3% |
| BrD | Brownsville channery silt loam, 12 to 18 percent slopes | 1.0 | 0.3% |
| BrE | Brownsville channery silt loam, 18 to 25 percent slopes | 31.1 | 10.6% |
| BrF | Brownsville channery silt loam, 25 to 35 percent slopes | 7.6 | 2.6% |
| Cen1B1 | Centerburg silt loam, 2 to 6 percent slopes | 3.3 | 1.1% |
| Cen1C2 | Centerburg silt loam, 6 to 12 percent slopes, eroded | 22.1 | 7.5% |
| GfA | Glenford silt loam, 0 to 2 percent slopes | 4.6 | 1.6% |
| GfB | Glenford silt loam, 2 to 6 percent slopes | 10.3 | 3.5% |
| Lu | Luray silty clay loam | 4.6 | 1.6% |
| McC2 | Mechanicsburg silt loam, 6 to 12 percent slopes, eroded | 26.4 | 9.0% |
| McD2 | Mechanicsburg silt loam, 12 to 18 percent slopes, eroded | 28.4 | 9.7% |
| OcA | Ockley silt loam, Southern Ohio Till Plain, 0 to 2 percent slopes | 37.3 | 12.7% |
| OcB | Ockley silt loam, Southern Ohio Till Plain, 2 to 6 percent slopes | 17.0 | 5.8% |
| OcC2 | Ockley silt loam, 6 to 12 percent slopes, eroded | 6.8 | 2.3% |
| Sh | Shoals silt loam, 0 to 2 percent slopes, occasionally flooded | 66.1 | 22.5% |
| W | Water | 2.7 | 0.9% |
| Totals for Area of Interest | | 293.8 | 100.0% |

Map Unit Descriptions

The map units delineated on the detailed soil maps in a soil survey represent the soils or miscellaneous areas in the survey area. The map unit descriptions, along with the maps, can be used to determine the composition and properties of a unit.

A map unit delineation on a soil map represents an area dominated by one or more major kinds of soil or miscellaneous areas. A map unit is identified and named according to the taxonomic classification of the dominant soils. Within a taxonomic class there are precisely defined limits for the properties of the soils. On the landscape, however, the soils are natural phenomena, and they have the characteristic variability of all natural phenomena. Thus, the range of some observed properties may extend beyond the limits defined for a taxonomic class. Areas of soils of a single taxonomic class rarely, if ever, can be mapped without including areas of other taxonomic classes. Consequently, every map unit is made up of the soils or miscellaneous areas for which it is named and some minor components that belong to taxonomic classes other than those of the major soils.

Most minor soils have properties similar to those of the dominant soil or soils in the map unit, and thus they do not affect use and management. These are called noncontrasting, or similar, components. They may or may not be mentioned in a particular map unit description. Other minor components, however, have properties and behavioral characteristics divergent enough to affect use or to require different management. These are called contrasting, or dissimilar, components. They generally are in small areas and could not be mapped separately because of the scale used. Some small areas of strongly contrasting soils or miscellaneous areas are identified by a special symbol on the maps. If included in the database for a given area, the contrasting minor components are identified in the map unit descriptions along with some characteristics of each. A few areas of minor components may not have been observed, and consequently they are not mentioned in the descriptions, especially where the pattern was so complex that it was impractical to make enough observations to identify all the soils and miscellaneous areas on the landscape.

The presence of minor components in a map unit in no way diminishes the usefulness or accuracy of the data. The objective of mapping is not to delineate pure taxonomic classes but rather to separate the landscape into landforms or landform segments that have similar use and management requirements. The delineation of such segments on the map provides sufficient information for the development of resource plans. If intensive use of small areas is planned, however, onsite investigation is needed to define and locate the soils and miscellaneous areas.

An identifying symbol precedes the map unit name in the map unit descriptions. Each description includes general facts about the unit and gives important soil properties and qualities.

Soils that have profiles that are almost alike make up a *soil series*. Except for differences in texture of the surface layer, all the soils of a series have major horizons that are similar in composition, thickness, and arrangement.

Soils of one series can differ in texture of the surface layer, slope, stoniness, salinity, degree of erosion, and other characteristics that affect their use. On the basis of such differences, a soil series is divided into *soil phases*. Most of the areas

Custom Soil Resource Report

shown on the detailed soil maps are phases of soil series. The name of a soil phase commonly indicates a feature that affects use or management. For example, Alpha silt loam, 0 to 2 percent slopes, is a phase of the Alpha series.

Some map units are made up of two or more major soils or miscellaneous areas. These map units are complexes, associations, or undifferentiated groups.

A *complex* consists of two or more soils or miscellaneous areas in such an intricate pattern or in such small areas that they cannot be shown separately on the maps. The pattern and proportion of the soils or miscellaneous areas are somewhat similar in all areas. Alpha-Beta complex, 0 to 6 percent slopes, is an example.

An *association* is made up of two or more geographically associated soils or miscellaneous areas that are shown as one unit on the maps. Because of present or anticipated uses of the map units in the survey area, it was not considered practical or necessary to map the soils or miscellaneous areas separately. The pattern and relative proportion of the soils or miscellaneous areas are somewhat similar. Alpha-Beta association, 0 to 2 percent slopes, is an example.

An *undifferentiated group* is made up of two or more soils or miscellaneous areas that could be mapped individually but are mapped as one unit because similar interpretations can be made for use and management. The pattern and proportion of the soils or miscellaneous areas in a mapped area are not uniform. An area can be made up of only one of the major soils or miscellaneous areas, or it can be made up of all of them. Alpha and Beta soils, 0 to 2 percent slopes, is an example.

Some surveys include *miscellaneous areas*. Such areas have little or no soil material and support little or no vegetation. Rock outcrop is an example.

Licking County, Ohio

AmB2—Amanda silt loam, 2 to 6 percent slopes, eroded

Map Unit Setting

National map unit symbol: 5qxq
Elevation: 900 to 1,200 feet
Mean annual precipitation: 36 to 39 inches
Mean annual air temperature: 50 to 54 degrees F
Frost-free period: 145 to 160 days
Farmland classification: All areas are prime farmland

Map Unit Composition

Amanda and similar soils: 100 percent
Estimates are based on observations, descriptions, and transects of the mapunit.

Description of Amanda

Setting

Landform: Ridges on till plains, knolls on till plains
Landform position (two-dimensional): Summit
Landform position (three-dimensional): Interfluve
Down-slope shape: Convex
Across-slope shape: Convex, linear
Parent material: Wisconsinan loamy till derived from sedimentary rock

Typical profile

H1 - 0 to 7 inches: silt loam
H2 - 7 to 28 inches: clay loam
H3 - 28 to 43 inches: clay loam
H4 - 43 to 60 inches: loam

Properties and qualities

Slope: 2 to 6 percent
Depth to restrictive feature: More than 80 inches
Drainage class: Well drained
Runoff class: Low
Capacity of the most limiting layer to transmit water (Ksat): Moderately high (0.20 to 0.60 in/hr)
Depth to water table: About 48 inches
Frequency of flooding: None
Frequency of ponding: None
Calcium carbonate, maximum content: 16 percent
Available water supply, 0 to 60 inches: High (about 9.3 inches)

Interpretive groups

Land capability classification (irrigated): None specified
Land capability classification (nonirrigated): 2e
Hydrologic Soil Group: C
Forage suitability group: Unnamed (G111EYA-1OH)
Other vegetative classification: Unnamed (G111EYA-1OH)
Hydric soil rating: No

AmC2—Amanda silt loam, 6 to 12 percent slopes, eroded

Map Unit Setting

National map unit symbol: 5qxr
Elevation: 900 to 1,200 feet
Mean annual precipitation: 36 to 39 inches
Mean annual air temperature: 50 to 54 degrees F
Frost-free period: 145 to 160 days
Farmland classification: Farmland of local importance

Map Unit Composition

Amanda and similar soils: 100 percent
Estimates are based on observations, descriptions, and transects of the mapunit.

Description of Amanda

Setting

Landform: Valleys on till plains, ridges on till plains, knolls on till plains
Landform position (two-dimensional): Summit, backslope
Landform position (three-dimensional): Interfluve, side slope
Down-slope shape: Convex
Across-slope shape: Convex, linear
Parent material: Wisconsinan loamy till derived from sedimentary rock

Typical profile

H1 - 0 to 6 inches: silt loam
H2 - 6 to 28 inches: clay loam
H3 - 28 to 45 inches: clay loam
H4 - 45 to 60 inches: loam

Properties and qualities

Slope: 6 to 12 percent
Depth to restrictive feature: More than 80 inches
Drainage class: Well drained
Runoff class: Medium
Capacity of the most limiting layer to transmit water (Ksat): Moderately high (0.20 to 0.60 in/hr)
Depth to water table: About 48 inches
Frequency of flooding: None
Frequency of ponding: None
Calcium carbonate, maximum content: 16 percent
Available water supply, 0 to 60 inches: High (about 9.4 inches)

Interpretive groups

Land capability classification (irrigated): None specified
Land capability classification (nonirrigated): 3e
Hydrologic Soil Group: C
Forage suitability group: Unnamed (G111EYA-1OH)
Other vegetative classification: Unnamed (G111EYA-1OH)
Hydric soil rating: No

Amd2—Amanda silt loam, 12 to 18 percent slopes, eroded

Map Unit Setting

National map unit symbol: 5qxs
Elevation: 900 to 1,200 feet
Mean annual precipitation: 36 to 39 inches
Mean annual air temperature: 50 to 54 degrees F
Frost-free period: 145 to 160 days
Farmland classification: Farmland of local importance

Map Unit Composition

Amanda and similar soils: 100 percent
Estimates are based on observations, descriptions, and transects of the mapunit.

Description of Amanda

Setting

Landform: Knolls on till plains, valleys on till plains
Landform position (two-dimensional): Backslope, summit
Landform position (three-dimensional): Interfluve, side slope
Down-slope shape: Convex, linear
Across-slope shape: Convex, linear
Parent material: Wisconsinan loamy till derived from sedimentary rock

Typical profile

H1 - 0 to 6 inches: silt loam
H2 - 6 to 28 inches: clay loam
H3 - 28 to 41 inches: clay loam
H4 - 41 to 60 inches: loam

Properties and qualities

Slope: 12 to 18 percent
Depth to restrictive feature: More than 80 inches
Drainage class: Well drained
Runoff class: Medium
Capacity of the most limiting layer to transmit water (Ksat): Moderately high (0.20 to 0.60 in/hr)
Depth to water table: About 48 inches
Frequency of flooding: None
Frequency of ponding: None
Calcium carbonate, maximum content: 16 percent
Available water supply, 0 to 60 inches: High (about 9.2 inches)

Interpretive groups

Land capability classification (irrigated): None specified
Land capability classification (nonirrigated): 4e
Hydrologic Soil Group: C
Forage suitability group: Unnamed (G111EYA-1OH)
Other vegetative classification: Unnamed (G111EYA-1OH)
Hydric soil rating: No

BrD—Brownsville channery silt loam, 12 to 18 percent slopes

Map Unit Setting

National map unit symbol: 2zfvk
Elevation: 770 to 1,230 feet
Mean annual precipitation: 37 to 45 inches
Mean annual air temperature: 50 to 55 degrees F
Frost-free period: 160 to 180 days
Farmland classification: Farmland of local importance

Map Unit Composition

Brownsville and similar soils: 75 percent
Minor components: 25 percent
Estimates are based on observations, descriptions, and transects of the mapunit.

Description of Brownsville

Setting

Landform: Hillslopes
Landform position (two-dimensional): Backslope, shoulder
Landform position (three-dimensional): Side slope
Down-slope shape: Convex, linear
Across-slope shape: Linear
Parent material: Loamy residuum weathered from sandstone and siltstone

Typical profile

A - 0 to 4 inches: channery silt loam
EB - 4 to 7 inches: channery silt loam
Bw1 - 7 to 18 inches: very channery silt loam
Bw2 - 18 to 36 inches: very channery silt loam
C - 36 to 50 inches: very channery silt loam
R - 50 to 60 inches: bedrock

Properties and qualities

Slope: 12 to 18 percent
Depth to restrictive feature: 41 to 72 inches to lithic bedrock
Drainage class: Well drained
Runoff class: Medium
Capacity of the most limiting layer to transmit water (Ksat): Moderately high to high
(0.20 to 2.00 in/hr)
Depth to water table: More than 80 inches
Frequency of flooding: None
Frequency of ponding: None
Available water supply, 0 to 60 inches: Low (about 5.0 inches)

Interpretive groups

Land capability classification (irrigated): None specified
Land capability classification (nonirrigated): 4e
Hydrologic Soil Group: A
Ecological site: F124XY002OH - Acid Mixed Sedimentary Upland
Forage suitability group: Unnamed (G124XYB-1OH)

Custom Soil Resource Report

Other vegetative classification: Unnamed (G124XYB-1OH)
Hydric soil rating: No

Minor Components

Coshocton

Percent of map unit: 10 percent
Landform: Hillslopes
Landform position (two-dimensional): Backslope
Landform position (three-dimensional): Side slope, base slope
Down-slope shape: Concave, linear
Across-slope shape: Linear
Hydric soil rating: No

Berks

Percent of map unit: 10 percent
Landform: Hillslopes
Landform position (two-dimensional): Shoulder, backslope
Landform position (three-dimensional): Side slope
Down-slope shape: Convex, linear
Across-slope shape: Linear
Hydric soil rating: No

Mechanicsburg

Percent of map unit: 5 percent
Landform: Hillslopes
Landform position (two-dimensional): Backslope
Landform position (three-dimensional): Side slope
Down-slope shape: Linear
Across-slope shape: Linear
Hydric soil rating: No

BrE—Brownsville channery silt loam, 18 to 25 percent slopes

Map Unit Setting

National map unit symbol: 5qy5
Elevation: 790 to 1,210 feet
Mean annual precipitation: 37 to 45 inches
Mean annual air temperature: 50 to 55 degrees F
Frost-free period: 160 to 180 days
Farmland classification: Not prime farmland

Map Unit Composition

Brownsville and similar soils: 100 percent
Estimates are based on observations, descriptions, and transects of the mapunit.

Description of Brownsville

Setting

Landform: Hills
Landform position (two-dimensional): Backslope

Custom Soil Resource Report

Landform position (three-dimensional): Side slope

Down-slope shape: Linear

Across-slope shape: Linear

Parent material: Acid, stony loamy colluvium derived from sandstone and siltstone
over acid, very stony loamy residuum weathered from sandstone and siltstone

Typical profile

H1 - 0 to 6 inches: channery silt loam

H2 - 6 to 41 inches: very channery silt loam

H3 - 41 to 51 inches: very channery silt loam

H4 - 51 to 53 inches: weathered bedrock

Properties and qualities

Slope: 18 to 25 percent

Depth to restrictive feature: 40 to 72 inches to paralithic bedrock

Drainage class: Well drained

Runoff class: High

Capacity of the most limiting layer to transmit water (Ksat): Moderately high (0.20
to 0.60 in/hr)

Depth to water table: More than 80 inches

Frequency of flooding: None

Frequency of ponding: None

Available water supply, 0 to 60 inches: Low (about 5.4 inches)

Interpretive groups

Land capability classification (irrigated): None specified

Land capability classification (nonirrigated): 4e

Hydrologic Soil Group: A

Ecological site: F124XY002OH - Acid Mixed Sedimentary Upland

Forage suitability group: Unnamed (G124XYB-1OH)

Other vegetative classification: Unnamed (G124XYB-1OH)

Hydric soil rating: No

BrF—Brownsville channery silt loam, 25 to 35 percent slopes

Map Unit Setting

National map unit symbol: 2z51z

Elevation: 770 to 1,340 feet

Mean annual precipitation: 37 to 44 inches

Mean annual air temperature: 48 to 54 degrees F

Frost-free period: 110 to 200 days

Farmland classification: Not prime farmland

Map Unit Composition

Brownsville and similar soils: 85 percent

Minor components: 15 percent

Estimates are based on observations, descriptions, and transects of the mapunit.

Description of Brownsville

Setting

Landform: Hillslopes

Custom Soil Resource Report

Landform position (two-dimensional): Backslope, shoulder

Landform position (three-dimensional): Side slope

Down-slope shape: Convex, linear

Across-slope shape: Linear

Parent material: Loamy residuum weathered from sandstone and siltstone

Typical profile

O_i - 0 to 1 inches: slightly decomposed plant material

A - 1 to 6 inches: channery silt loam

E - 6 to 12 inches: channery silt loam

Bw₁ - 12 to 18 inches: very channery silt loam

Bw₂ - 18 to 36 inches: very channery silt loam

C - 36 to 50 inches: very channery silt loam

R - 50 to 60 inches: bedrock

Properties and qualities

Slope: 25 to 35 percent

Depth to restrictive feature: 41 to 72 inches to lithic bedrock

Drainage class: Well drained

Runoff class: High

Capacity of the most limiting layer to transmit water (K_{sat}): Moderately high to high
(0.20 to 2.00 in/hr)

Depth to water table: More than 80 inches

Frequency of flooding: None

Frequency of ponding: None

Available water supply, 0 to 60 inches: Low (about 5.0 inches)

Interpretive groups

Land capability classification (irrigated): None specified

Land capability classification (nonirrigated): 6e

Hydrologic Soil Group: A

Ecological site: F124XY002OH - Acid Mixed Sedimentary Upland

Forage suitability group: Unnamed (G124XYB-2OH)

Other vegetative classification: Unnamed (G124XYB-2OH)

Hydric soil rating: No

Minor Components

Coshocton

Percent of map unit: 5 percent

Landform: Hillslopes

Landform position (two-dimensional): Backslope, footslope

Landform position (three-dimensional): Side slope, base slope, head slope

Down-slope shape: Concave, linear

Across-slope shape: Linear, concave

Hydric soil rating: No

Berks

Percent of map unit: 5 percent

Landform: Hillslopes

Landform position (two-dimensional): Backslope, shoulder

Landform position (three-dimensional): Side slope, nose slope

Down-slope shape: Convex

Across-slope shape: Linear, convex

Hydric soil rating: No

Custom Soil Resource Report

Westmoreland

Percent of map unit: 2 percent
Landform: Hillslopes
Landform position (two-dimensional): Backslope, footslope
Landform position (three-dimensional): Side slope, base slope
Down-slope shape: Linear
Across-slope shape: Linear
Hydric soil rating: No

Brownsville, bouldery

Percent of map unit: 1 percent
Landform: Hillslopes
Landform position (two-dimensional): Footslope
Landform position (three-dimensional): Base slope
Down-slope shape: Concave, linear
Across-slope shape: Linear
Hydric soil rating: No

Orrville

Percent of map unit: 1 percent
Landform: Flood-plain steps
Landform position (three-dimensional): Tread
Down-slope shape: Concave, linear
Across-slope shape: Linear
Hydric soil rating: No

Unnamed

Percent of map unit: 1 percent
Landform: Hillslopes
Landform position (two-dimensional): Backslope
Landform position (three-dimensional): Head slope
Down-slope shape: Concave
Across-slope shape: Concave
Hydric soil rating: No

Rock outcrop

Percent of map unit: 0 percent
Hydric soil rating: No

Cen1B1—Centerburg silt loam, 2 to 6 percent slopes

Map Unit Setting

National map unit symbol: 2wvgc
Elevation: 780 to 1,400 feet
Mean annual precipitation: 36 to 42 inches
Mean annual air temperature: 48 to 54 degrees F
Frost-free period: 145 to 170 days
Farmland classification: All areas are prime farmland

Map Unit Composition

Centerburg and similar soils: 85 percent

Minor components: 15 percent

Estimates are based on observations, descriptions, and transects of the mapunit.

Description of Centerburg

Setting

Landform: Ground moraines, end moraines

Landform position (two-dimensional): Summit, shoulder, backslope

Landform position (three-dimensional): Side slope, crest

Down-slope shape: Linear, convex

Across-slope shape: Convex

Parent material: Wisconsin loamy till derived from sandstone and shale

Typical profile

Ap - 0 to 9 inches: silt loam

Bt1 - 9 to 21 inches: silty clay loam

Bt2 - 21 to 35 inches: clay loam

BC - 35 to 40 inches: clay loam

C - 40 to 79 inches: loam

Properties and qualities

Slope: 2 to 6 percent

Depth to restrictive feature: More than 80 inches

Drainage class: Moderately well drained

Runoff class: Low

Capacity of the most limiting layer to transmit water (Ksat): Moderately high (0.20 to 0.60 in/hr)

Depth to water table: About 12 to 24 inches

Frequency of flooding: None

Frequency of ponding: None

Calcium carbonate, maximum content: 22 percent

Maximum salinity: Nonsaline to very slightly saline (0.0 to 2.0 mmhos/cm)

Available water supply, 0 to 60 inches: Moderate (about 8.5 inches)

Interpretive groups

Land capability classification (irrigated): None specified

Land capability classification (nonirrigated): 2e

Hydrologic Soil Group: C/D

Ecological site: F111XE503OH - Till Ridge

Forage suitability group: Unnamed (G111EYA-6OH)

Other vegetative classification: Unnamed (G111EYA-6OH)

Hydric soil rating: No

Minor Components

Bennington

Percent of map unit: 8 percent

Landform: End moraines, ground moraines

Landform position (two-dimensional): Footslope, backslope, summit

Landform position (three-dimensional): Interfluve

Down-slope shape: Concave, linear

Across-slope shape: Linear

Ecological site: F111XE502OH - Wet Till Ridge

Hydric soil rating: No

Condit

Percent of map unit: 4 percent
Landform: Depressions, drainageways
Landform position (two-dimensional): Toeslope
Landform position (three-dimensional): Base slope
Down-slope shape: Concave, linear
Across-slope shape: Concave
Ecological site: F111XE501OH - Till Depression
Hydric soil rating: Yes

Marengo

Percent of map unit: 3 percent
Landform: Depressions, drainageways
Landform position (two-dimensional): Toeslope
Landform position (three-dimensional): Base slope
Down-slope shape: Concave, linear
Across-slope shape: Concave
Ecological site: F111XE501OH - Till Depression
Hydric soil rating: Yes

Cen1C2—Centerburg silt loam, 6 to 12 percent slopes, eroded

Map Unit Setting

National map unit symbol: 2wp1y
Elevation: 780 to 1,400 feet
Mean annual precipitation: 36 to 42 inches
Mean annual air temperature: 48 to 54 degrees F
Frost-free period: 145 to 170 days
Farmland classification: Farmland of local importance

Map Unit Composition

Centerburg, eroded, and similar soils: 85 percent
Minor components: 15 percent
Estimates are based on observations, descriptions, and transects of the mapunit.

Description of Centerburg, Eroded

Setting

Landform: End moraines, ground moraines
Landform position (two-dimensional): Shoulder, backslope
Landform position (three-dimensional): Crest, side slope
Down-slope shape: Convex
Across-slope shape: Convex, linear
Parent material: Wisconsin loamy till derived from sandstone and shale

Typical profile

Ap - 0 to 7 inches: silt loam
Bt1 - 7 to 18 inches: silty clay loam
Bt2 - 18 to 31 inches: clay loam
BC - 31 to 36 inches: clay loam

Custom Soil Resource Report

C - 36 to 79 inches: loam

Properties and qualities

Slope: 6 to 12 percent

Depth to restrictive feature: More than 80 inches

Drainage class: Moderately well drained

Runoff class: Medium

Capacity of the most limiting layer to transmit water (Ksat): Moderately high (0.20 to 0.60 in/hr)

Depth to water table: About 12 to 24 inches

Frequency of flooding: None

Frequency of ponding: None

Calcium carbonate, maximum content: 22 percent

Maximum salinity: Nonsaline to very slightly saline (0.0 to 2.0 mmhos/cm)

Available water supply, 0 to 60 inches: Moderate (about 7.9 inches)

Interpretive groups

Land capability classification (irrigated): None specified

Land capability classification (nonirrigated): 2e

Hydrologic Soil Group: C/D

Ecological site: F111XE503OH - Till Ridge

Hydric soil rating: No

Minor Components

Amanda, severely eroded

Percent of map unit: 6 percent

Landform: End moraines, ground moraines

Landform position (two-dimensional): Shoulder, backslope

Landform position (three-dimensional): Side slope

Down-slope shape: Convex

Across-slope shape: Linear

Ecological site: F111XE503OH - Till Ridge

Hydric soil rating: No

Bennington

Percent of map unit: 5 percent

Landform: End moraines, ground moraines

Landform position (two-dimensional): Footslope, backslope

Landform position (three-dimensional): Interfluvium

Down-slope shape: Concave, linear

Across-slope shape: Linear

Ecological site: F111XE502OH - Wet Till Ridge

Hydric soil rating: No

Condit

Percent of map unit: 4 percent

Landform: Depressions, drainageways

Landform position (two-dimensional): Toeslope

Landform position (three-dimensional): Base slope

Down-slope shape: Concave, linear

Across-slope shape: Concave

Ecological site: F111XE501OH - Till Depression

Hydric soil rating: Yes

GfA—Glenford silt loam, 0 to 2 percent slopes

Map Unit Setting

National map unit symbol: 5qz3
Elevation: 690 to 1,110 feet
Mean annual precipitation: 31 to 40 inches
Mean annual air temperature: 46 to 55 degrees F
Frost-free period: 130 to 193 days
Farmland classification: All areas are prime farmland

Map Unit Composition

Glenford and similar soils: 95 percent
Minor components: 5 percent
Estimates are based on observations, descriptions, and transects of the mapunit.

Description of Glenford

Setting

Landform: Draws, flats on lake plains, flats on terraces
Landform position (two-dimensional): Toeslope
Landform position (three-dimensional): Base slope, tread, rise
Down-slope shape: Concave, linear
Across-slope shape: Linear
Parent material: Silty glaciolacustrine deposits derived from interbedded sedimentary rock

Typical profile

H1 - 0 to 8 inches: silt loam
H2 - 8 to 39 inches: silt loam
H3 - 39 to 52 inches: silt loam
H4 - 52 to 60 inches: silt loam

Properties and qualities

Slope: 0 to 2 percent
Depth to restrictive feature: More than 80 inches
Drainage class: Moderately well drained
Runoff class: Low
Capacity of the most limiting layer to transmit water (Ksat): Moderately high (0.20 to 0.60 in/hr)
Depth to water table: About 24 to 42 inches
Frequency of flooding: None
Frequency of ponding: None
Calcium carbonate, maximum content: 5 percent
Available water supply, 0 to 60 inches: High (about 9.5 inches)

Interpretive groups

Land capability classification (irrigated): None specified
Land capability classification (nonirrigated): 1
Hydrologic Soil Group: C
Forage suitability group: Unnamed (G114AYA-6OH)

Custom Soil Resource Report

Other vegetative classification: Unnamed (G114AYA-6OH)
Hydric soil rating: No

Minor Components

Luray

Percent of map unit: 5 percent
Landform: Lake terraces
Hydric soil rating: Yes

GfB—Glenford silt loam, 2 to 6 percent slopes

Map Unit Setting

National map unit symbol: 5qz4
Elevation: 690 to 1,110 feet
Mean annual precipitation: 31 to 40 inches
Mean annual air temperature: 46 to 55 degrees F
Frost-free period: 130 to 193 days
Farmland classification: All areas are prime farmland

Map Unit Composition

Glenford and similar soils: 90 percent
Minor components: 10 percent
Estimates are based on observations, descriptions, and transects of the mapunit.

Description of Glenford

Setting

Landform: Hills, knolls on terraces, knolls on lake plains
Landform position (two-dimensional): Footslope, summit
Landform position (three-dimensional): Base slope, tread, rise
Down-slope shape: Concave, convex
Across-slope shape: Linear, convex
Parent material: Silty glaciolacustrine deposits derived from interbedded sedimentary rock

Typical profile

H1 - 0 to 9 inches: silt loam
H2 - 9 to 39 inches: silt loam
H3 - 39 to 45 inches: silt loam
H4 - 45 to 60 inches: silt loam

Properties and qualities

Slope: 2 to 6 percent
Depth to restrictive feature: More than 80 inches
Drainage class: Moderately well drained
Runoff class: Medium
Capacity of the most limiting layer to transmit water (Ksat): Moderately high (0.20 to 0.60 in/hr)
Depth to water table: About 24 to 42 inches
Frequency of flooding: None

Custom Soil Resource Report

Frequency of ponding: None
Calcium carbonate, maximum content: 5 percent
Available water supply, 0 to 60 inches: High (about 9.5 inches)

Interpretive groups

Land capability classification (irrigated): None specified
Land capability classification (nonirrigated): 2e
Hydrologic Soil Group: C
Forage suitability group: Unnamed (G114AYA-6OH)
Other vegetative classification: Unnamed (G114AYA-6OH)
Hydric soil rating: No

Minor Components

Luray

Percent of map unit: 5 percent
Landform: Depressions
Hydric soil rating: Yes

Sebring

Percent of map unit: 5 percent
Landform: Draws
Hydric soil rating: Yes

Lu—Luray silty clay loam

Map Unit Setting

National map unit symbol: 5qzm
Elevation: 890 to 1,120 feet
Mean annual precipitation: 34 to 40 inches
Mean annual air temperature: 50 to 54 degrees F
Frost-free period: 146 to 166 days
Farmland classification: Prime farmland if drained

Map Unit Composition

Luray and similar soils: 100 percent
Estimates are based on observations, descriptions, and transects of the mapunit.

Description of Luray

Setting

Landform: Depressions on terraces, depressions on lake plains, flats on terraces, flats on lake plains
Landform position (three-dimensional): Dip, talf
Down-slope shape: Concave, linear
Across-slope shape: Concave, linear
Parent material: Silty lacustrine deposits derived from interbedded sedimentary rock

Typical profile

H1 - 0 to 12 inches: silty clay loam

Custom Soil Resource Report

H2 - 12 to 40 inches: silty clay loam

H3 - 40 to 60 inches: stratified fine sandy loam to silty clay loam

Properties and qualities

Slope: 0 to 2 percent

Depth to restrictive feature: More than 80 inches

Drainage class: Very poorly drained

Runoff class: Negligible

Capacity of the most limiting layer to transmit water (Ksat): Moderately high (0.20 to 0.60 in/hr)

Depth to water table: About 0 to 12 inches

Frequency of flooding: None

Frequency of ponding: Frequent

Calcium carbonate, maximum content: 5 percent

Available water supply, 0 to 60 inches: High (about 11.4 inches)

Interpretive groups

Land capability classification (irrigated): None specified

Land capability classification (nonirrigated): 2w

Hydrologic Soil Group: C/D

Hydric soil rating: Yes

McC2—Mechanicsburg silt loam, 6 to 12 percent slopes, eroded

Map Unit Setting

National map unit symbol: 5qzp

Elevation: 1,120 to 1,170 feet

Mean annual precipitation: 49 to 53 inches

Mean annual air temperature: 36 to 39 degrees F

Frost-free period: 146 to 153 days

Farmland classification: Farmland of local importance

Map Unit Composition

Mechanicsburg and similar soils: 100 percent

Estimates are based on observations, descriptions, and transects of the mapunit.

Description of Mechanicsburg

Setting

Landform: Hills

Landform position (two-dimensional): Shoulder, summit

Landform position (three-dimensional): Side slope, interfluvium

Down-slope shape: Convex

Across-slope shape: Linear

Parent material: Loamy till derived from interbedded sedimentary rock over loamy residuum weathered from sandstone and siltstone

Typical profile

H1 - 0 to 7 inches: silt loam

H2 - 7 to 29 inches: loam

H3 - 29 to 35 inches: channery loam

H4 - 35 to 60 inches: very channery silt loam

Custom Soil Resource Report

H5 - 60 to 62 inches: unweathered bedrock

Properties and qualities

Slope: 6 to 12 percent

Depth to restrictive feature: 40 to 72 inches to paralithic bedrock

Drainage class: Well drained

Runoff class: High

*Capacity of the most limiting layer to transmit water (Ksat): Moderately high to high
(0.20 to 2.00 in/hr)*

Depth to water table: More than 80 inches

Frequency of flooding: None

Frequency of ponding: None

Available water supply, 0 to 60 inches: Moderate (about 7.8 inches)

Interpretive groups

Land capability classification (irrigated): None specified

Land capability classification (nonirrigated): 3e

Hydrologic Soil Group: B

Forage suitability group: Unnamed (G114AYA-1OH)

Other vegetative classification: Unnamed (G114AYA-1OH)

Hydric soil rating: No

McD2—Mechanicsburg silt loam, 12 to 18 percent slopes, eroded

Map Unit Setting

National map unit symbol: 5qzq

Elevation: 1,120 to 1,170 feet

Mean annual precipitation: 49 to 53 inches

Mean annual air temperature: 36 to 39 degrees F

Frost-free period: 146 to 153 days

Farmland classification: Farmland of local importance

Map Unit Composition

Mechanicsburg and similar soils: 100 percent

Estimates are based on observations, descriptions, and transects of the mapunit.

Description of Mechanicsburg

Setting

Landform: Hills

Landform position (two-dimensional): Backslope

Landform position (three-dimensional): Side slope

Down-slope shape: Linear

Across-slope shape: Linear

*Parent material: Loamy till derived from interbedded sedimentary rock over loamy
residuum weathered from sandstone and siltstone*

Typical profile

H1 - 0 to 7 inches: silt loam

H2 - 7 to 29 inches: loam

H3 - 29 to 51 inches: channery loam

H4 - 51 to 60 inches: very channery silt loam

Custom Soil Resource Report

H5 - 60 to 62 inches: unweathered bedrock

Properties and qualities

Slope: 12 to 18 percent

Depth to restrictive feature: 40 to 72 inches to paralithic bedrock

Drainage class: Well drained

Runoff class: High

*Capacity of the most limiting layer to transmit water (Ksat): Moderately high to high
(0.20 to 2.00 in/hr)*

Depth to water table: More than 80 inches

Frequency of flooding: None

Frequency of ponding: None

Available water supply, 0 to 60 inches: Moderate (about 8.8 inches)

Interpretive groups

Land capability classification (irrigated): None specified

Land capability classification (nonirrigated): 4e

Hydrologic Soil Group: B

Forage suitability group: Unnamed (G114AYA-1OH)

Other vegetative classification: Unnamed (G114AYA-1OH)

Hydric soil rating: No

OcA—Ockley silt loam, Southern Ohio Till Plain, 0 to 2 percent slopes

Map Unit Setting

National map unit symbol: 2t4lh

Elevation: 400 to 1,300 feet

Mean annual precipitation: 35 to 45 inches

Mean annual air temperature: 48 to 55 degrees F

Frost-free period: 125 to 190 days

Farmland classification: All areas are prime farmland

Map Unit Composition

Ockley and similar soils: 85 percent

Minor components: 15 percent

Estimates are based on observations, descriptions, and transects of the mapunit.

Description of Ockley

Setting

Landform: Outwash terraces

Landform position (two-dimensional): Summit

Landform position (three-dimensional): Tread

Down-slope shape: Linear

Across-slope shape: Linear

Parent material: Loess over loamy outwash over stratified sandy and gravelly outwash

Typical profile

Ap - 0 to 9 inches: silt loam

Bt1 - 9 to 20 inches: silty clay loam

2Bt2 - 20 to 64 inches: gravelly clay loam

Custom Soil Resource Report

3C - 64 to 79 inches: gravelly loamy sand

Properties and qualities

Slope: 0 to 2 percent

Depth to restrictive feature: 40 to 70 inches to strongly contrasting textural stratification

Drainage class: Well drained

Runoff class: Low

Capacity of the most limiting layer to transmit water (Ksat): Moderately high to high (0.60 to 2.00 in/hr)

Depth to water table: More than 80 inches

Frequency of flooding: None

Frequency of ponding: None

Calcium carbonate, maximum content: 50 percent

Maximum salinity: Nonsaline to very slightly saline (0.0 to 2.0 mmhos/cm)

Available water supply, 0 to 60 inches: Moderate (about 8.9 inches)

Interpretive groups

Land capability classification (irrigated): None specified

Land capability classification (nonirrigated): 1

Hydrologic Soil Group: B

Ecological site: F111XA015IN - Dry Outwash Upland

Hydric soil rating: No

Minor Components

Fox

Percent of map unit: 5 percent

Landform: Outwash plains, terraces

Landform position (two-dimensional): Summit

Landform position (three-dimensional): Tread, talf

Down-slope shape: Convex

Across-slope shape: Linear

Ecological site: F111XA015IN - Dry Outwash Upland

Hydric soil rating: No

Sleeth

Percent of map unit: 5 percent

Landform: Stream terraces, outwash terraces

Landform position (two-dimensional): Shoulder, backslope

Landform position (three-dimensional): Tread

Down-slope shape: Linear

Across-slope shape: Linear

Ecological site: F111XA014IN - Outwash Upland

Hydric soil rating: No

Eldean

Percent of map unit: 5 percent

Landform: Outwash terraces

Landform position (two-dimensional): Shoulder, backslope

Landform position (three-dimensional): Tread

Down-slope shape: Linear

Across-slope shape: Linear

Ecological site: F111XA015IN - Dry Outwash Upland

Hydric soil rating: No

OcB—Ockley silt loam, Southern Ohio Till Plain, 2 to 6 percent slopes

Map Unit Setting

National map unit symbol: 2t4ln
Elevation: 400 to 1,300 feet
Mean annual precipitation: 37 to 46 inches
Mean annual air temperature: 48 to 55 degrees F
Frost-free period: 155 to 180 days
Farmland classification: All areas are prime farmland

Map Unit Composition

Ockley and similar soils: 85 percent
Minor components: 15 percent
Estimates are based on observations, descriptions, and transects of the mapunit.

Description of Ockley

Setting

Landform: Outwash terraces
Landform position (two-dimensional): Shoulder
Landform position (three-dimensional): Tread
Down-slope shape: Linear
Across-slope shape: Linear
Parent material: Loess over loamy outwash over sandy and gravelly outwash

Typical profile

Ap - 0 to 10 inches: silt loam
2Bt1 - 10 to 41 inches: clay loam
2Bt2 - 41 to 66 inches: gravelly clay loam
3C - 66 to 79 inches: gravelly loamy coarse sand

Properties and qualities

Slope: 2 to 6 percent
Depth to restrictive feature: 40 to 70 inches to strongly contrasting textural stratification
Drainage class: Well drained
Runoff class: Low
Capacity of the most limiting layer to transmit water (Ksat): Moderately high to high (0.60 to 2.00 in/hr)
Depth to water table: More than 80 inches
Frequency of flooding: None
Frequency of ponding: None
Calcium carbonate, maximum content: 50 percent
Maximum salinity: Nonsaline to very slightly saline (0.0 to 2.0 mmhos/cm)
Available water supply, 0 to 60 inches: High (about 9.7 inches)

Interpretive groups

Land capability classification (irrigated): None specified
Land capability classification (nonirrigated): 2e
Hydrologic Soil Group: B

Custom Soil Resource Report

Ecological site: F111XA015IN - Dry Outwash Upland, F111XD018IN - Dry Outwash Upland
Hydric soil rating: No

Minor Components

Sleeth

Percent of map unit: 5 percent
Landform: Stream terraces, outwash terraces
Landform position (two-dimensional): Shoulder, backslope
Landform position (three-dimensional): Tread
Down-slope shape: Linear
Across-slope shape: Linear
Ecological site: F111XA014IN - Outwash Upland
Hydric soil rating: No

Eldean

Percent of map unit: 5 percent
Landform: Outwash terraces
Landform position (two-dimensional): Shoulder, backslope
Landform position (three-dimensional): Tread
Down-slope shape: Linear
Across-slope shape: Linear
Ecological site: F111XA015IN - Dry Outwash Upland
Hydric soil rating: No

Fox

Percent of map unit: 5 percent
Landform: Outwash plains, terraces
Landform position (two-dimensional): Summit
Landform position (three-dimensional): Tread, talf
Down-slope shape: Convex
Across-slope shape: Linear
Ecological site: F111XA015IN - Dry Outwash Upland
Hydric soil rating: No

OcC2—Ockley silt loam, 6 to 12 percent slopes, eroded

Map Unit Setting

National map unit symbol: 5r06
Elevation: 400 to 1,000 feet
Mean annual precipitation: 35 to 45 inches
Mean annual air temperature: 46 to 54 degrees F
Frost-free period: 130 to 180 days
Farmland classification: Farmland of local importance

Map Unit Composition

Ockley and similar soils: 100 percent
Estimates are based on observations, descriptions, and transects of the mapunit.

Description of Ockley

Setting

Landform: Kames, drainageways on terraces
Landform position (two-dimensional): Backslope
Landform position (three-dimensional): Riser
Down-slope shape: Convex
Across-slope shape: Linear, convex
Parent material: Silty loess derived from interbedded sedimentary rock over calcareous, wisconsinan loamy outwash derived from interbedded sedimentary rock

Typical profile

H1 - 0 to 6 inches: silt loam
H2 - 6 to 50 inches: clay loam
H3 - 50 to 60 inches: very gravelly sand

Properties and qualities

Slope: 6 to 12 percent
Depth to restrictive feature: More than 80 inches
Drainage class: Well drained
Runoff class: Medium
Capacity of the most limiting layer to transmit water (Ksat): Moderately high to high (0.60 to 2.00 in/hr)
Depth to water table: More than 80 inches
Frequency of flooding: None
Frequency of ponding: None
Calcium carbonate, maximum content: 30 percent
Available water supply, 0 to 60 inches: Low (about 5.6 inches)

Interpretive groups

Land capability classification (irrigated): None specified
Land capability classification (nonirrigated): 3e
Hydrologic Soil Group: B
Hydric soil rating: No

Sh—Shoals silt loam, 0 to 2 percent slopes, occasionally flooded

Map Unit Setting

National map unit symbol: 2t6lp
Elevation: 340 to 1,000 feet
Mean annual precipitation: 34 to 42 inches
Mean annual air temperature: 48 to 55 degrees F
Frost-free period: 140 to 180 days
Farmland classification: Prime farmland if drained

Map Unit Composition

Shoals and similar soils: 85 percent
Minor components: 15 percent
Estimates are based on observations, descriptions, and transects of the mapunit.

Description of Shoals

Setting

Landform: Flood plains
Landform position (three-dimensional): Dip
Down-slope shape: Linear
Across-slope shape: Linear
Parent material: Loamy alluvium

Typical profile

Ap - 0 to 10 inches: silt loam
B - 10 to 42 inches: silt loam
C - 42 to 79 inches: stratified sandy loam to silt loam

Properties and qualities

Slope: 0 to 2 percent
Depth to restrictive feature: More than 80 inches
Drainage class: Somewhat poorly drained
Runoff class: Low
Capacity of the most limiting layer to transmit water (Ksat): Moderately high to high (0.60 to 2.00 in/hr)
Depth to water table: About 6 to 18 inches
Frequency of flooding: NoneOccasional
Frequency of ponding: None
Calcium carbonate, maximum content: 22 percent
Available water supply, 0 to 60 inches: High (about 10.0 inches)

Interpretive groups

Land capability classification (irrigated): None specified
Land capability classification (nonirrigated): 2w
Hydrologic Soil Group: B/D
Ecological site: F111XB203IN - Wet Alluvium Forest, F111XE203OH - Wet Alluvium Forest
Hydric soil rating: No

Minor Components

Sloan

Percent of map unit: 8 percent
Landform: Flood plains
Landform position (three-dimensional): Dip
Down-slope shape: Linear
Across-slope shape: Linear
Ecological site: F111XB201IN - Wet Alluvium Floodplain
Hydric soil rating: Yes

Eel

Percent of map unit: 7 percent
Landform: Flood plains
Landform position (three-dimensional): Rise
Down-slope shape: Linear
Across-slope shape: Linear
Ecological site: F111XB204IN - Dry Alluvium Forest
Hydric soil rating: No

W—Water

Map Unit Composition

Water: 100 percent

Estimates are based on observations, descriptions, and transects of the mapunit.

References

- American Association of State Highway and Transportation Officials (AASHTO). 2004. Standard specifications for transportation materials and methods of sampling and testing. 24th edition.
- American Society for Testing and Materials (ASTM). 2005. Standard classification of soils for engineering purposes. ASTM Standard D2487-00.
- Cowardin, L.M., V. Carter, F.C. Golet, and E.T. LaRoe. 1979. Classification of wetlands and deep-water habitats of the United States. U.S. Fish and Wildlife Service FWS/OBS-79/31.
- Federal Register. July 13, 1994. Changes in hydric soils of the United States.
- Federal Register. September 18, 2002. Hydric soils of the United States.
- Hurt, G.W., and L.M. Vasilas, editors. Version 6.0, 2006. Field indicators of hydric soils in the United States.
- National Research Council. 1995. Wetlands: Characteristics and boundaries.
- Soil Survey Division Staff. 1993. Soil survey manual. Soil Conservation Service. U.S. Department of Agriculture Handbook 18. http://www.nrcs.usda.gov/wps/portal/nrcs/detail/national/soils/?cid=nrcs142p2_054262
- Soil Survey Staff. 1999. Soil taxonomy: A basic system of soil classification for making and interpreting soil surveys. 2nd edition. Natural Resources Conservation Service, U.S. Department of Agriculture Handbook 436. http://www.nrcs.usda.gov/wps/portal/nrcs/detail/national/soils/?cid=nrcs142p2_053577
- Soil Survey Staff. 2010. Keys to soil taxonomy. 11th edition. U.S. Department of Agriculture, Natural Resources Conservation Service. http://www.nrcs.usda.gov/wps/portal/nrcs/detail/national/soils/?cid=nrcs142p2_053580
- Tiner, R.W., Jr. 1985. Wetlands of Delaware. U.S. Fish and Wildlife Service and Delaware Department of Natural Resources and Environmental Control, Wetlands Section.
- United States Army Corps of Engineers, Environmental Laboratory. 1987. Corps of Engineers wetlands delineation manual. Waterways Experiment Station Technical Report Y-87-1.
- United States Department of Agriculture, Natural Resources Conservation Service. National forestry manual. http://www.nrcs.usda.gov/wps/portal/nrcs/detail/soils/home/?cid=nrcs142p2_053374
- United States Department of Agriculture, Natural Resources Conservation Service. National range and pasture handbook. <http://www.nrcs.usda.gov/wps/portal/nrcs/detail/national/landuse/rangepasture/?cid=stelprdb1043084>

Custom Soil Resource Report

United States Department of Agriculture, Natural Resources Conservation Service. National soil survey handbook, title 430-VI. http://www.nrcs.usda.gov/wps/portal/nrcs/detail/soils/scientists/?cid=nrcs142p2_054242

United States Department of Agriculture, Natural Resources Conservation Service. 2006. Land resource regions and major land resource areas of the United States, the Caribbean, and the Pacific Basin. U.S. Department of Agriculture Handbook 296. http://www.nrcs.usda.gov/wps/portal/nrcs/detail/national/soils/?cid=nrcs142p2_053624

United States Department of Agriculture, Soil Conservation Service. 1961. Land capability classification. U.S. Department of Agriculture Handbook 210. http://www.nrcs.usda.gov/Internet/FSE_DOCUMENTS/nrcs142p2_052290.pdf



United States
Department of
Agriculture

NRCS

Natural
Resources
Conservation
Service

A product of the National
Cooperative Soil Survey,
a joint effort of the United
States Department of
Agriculture and other
Federal agencies, State
agencies including the
Agricultural Experiment
Stations, and local
participants

Custom Soil Resource Report for Licking County, Ohio

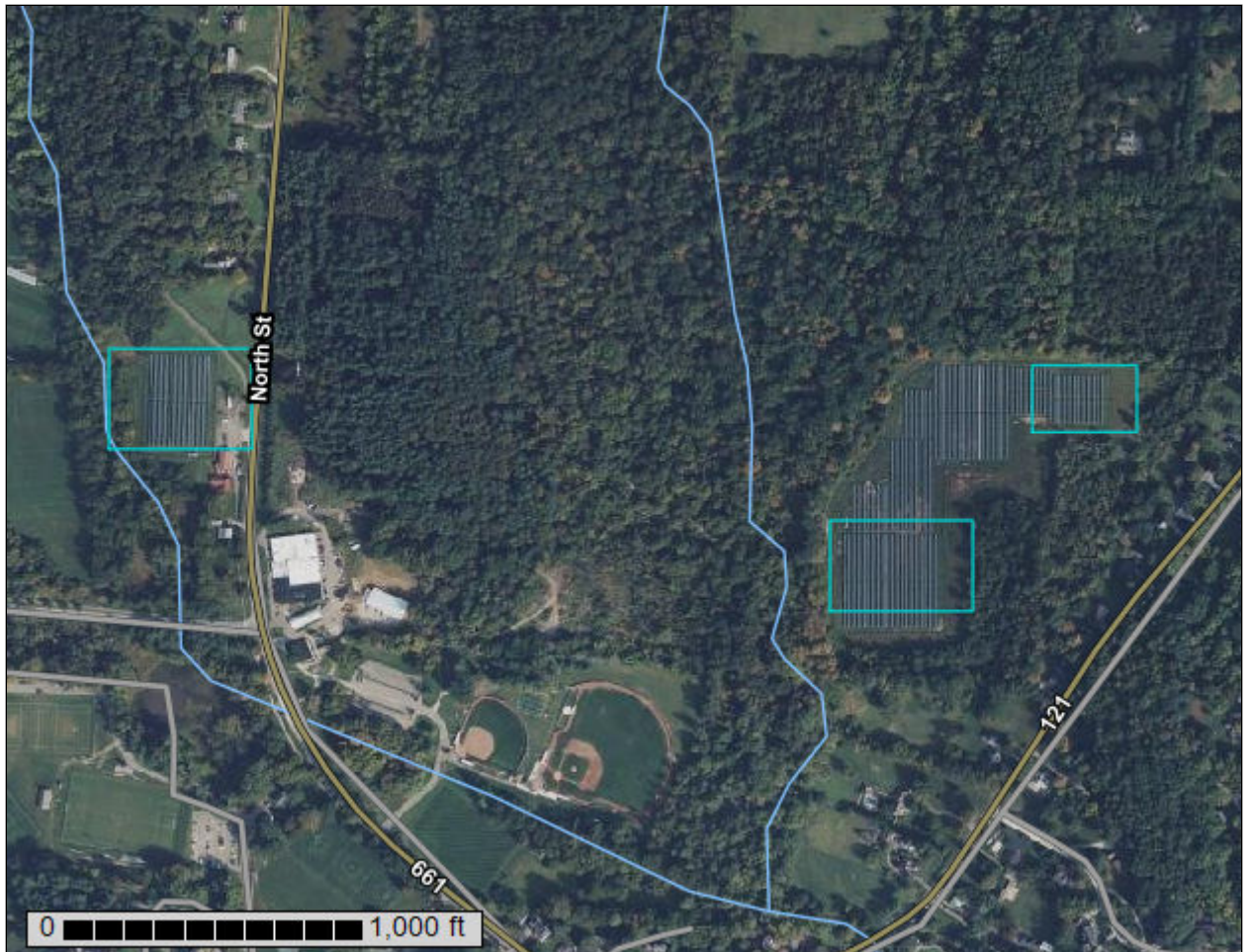

Preface

Soil surveys contain information that affects land use planning in survey areas. They highlight soil limitations that affect various land uses and provide information about the properties of the soils in the survey areas. Soil surveys are designed for many different users, including farmers, ranchers, foresters, agronomists, urban planners, community officials, engineers, developers, builders, and home buyers. Also, conservationists, teachers, students, and specialists in recreation, waste disposal, and pollution control can use the surveys to help them understand, protect, or enhance the environment.

Various land use regulations of Federal, State, and local governments may impose special restrictions on land use or land treatment. Soil surveys identify soil properties that are used in making various land use or land treatment decisions. The information is intended to help the land users identify and reduce the effects of soil limitations on various land uses. The landowner or user is responsible for identifying and complying with existing laws and regulations.

Although soil survey information can be used for general farm, local, and wider area planning, onsite investigation is needed to supplement this information in some cases. Examples include soil quality assessments (<http://www.nrcs.usda.gov/wps/portal/nrcs/main/soils/health/>) and certain conservation and engineering applications. For more detailed information, contact your local USDA Service Center (<https://offices.sc.egov.usda.gov/locator/app?agency=nrcs>) or your NRCS State Soil Scientist (http://www.nrcs.usda.gov/wps/portal/nrcs/detail/soils/contactus/?cid=nrcs142p2_053951).

Great differences in soil properties can occur within short distances. Some soils are seasonally wet or subject to flooding. Some are too unstable to be used as a foundation for buildings or roads. Clayey or wet soils are poorly suited to use as septic tank absorption fields. A high water table makes a soil poorly suited to basements or underground installations.

The National Cooperative Soil Survey is a joint effort of the United States Department of Agriculture and other Federal agencies, State agencies including the Agricultural Experiment Stations, and local agencies. The Natural Resources Conservation Service (NRCS) has leadership for the Federal part of the National Cooperative Soil Survey.

Information about soils is updated periodically. Updated information is available through the NRCS Web Soil Survey, the site for official soil survey information.

The U.S. Department of Agriculture (USDA) prohibits discrimination in all its programs and activities on the basis of race, color, national origin, age, disability, and where applicable, sex, marital status, familial status, parental status, religion, sexual orientation, genetic information, political beliefs, reprisal, or because all or a part of an individual's income is derived from any public assistance program. (Not all prohibited bases apply to all programs.) Persons with disabilities who require

alternative means for communication of program information (Braille, large print, audiotape, etc.) should contact USDA's TARGET Center at (202) 720-2600 (voice and TDD). To file a complaint of discrimination, write to USDA, Director, Office of Civil Rights, 1400 Independence Avenue, S.W., Washington, D.C. 20250-9410 or call (800) 795-3272 (voice) or (202) 720-6382 (TDD). USDA is an equal opportunity provider and employer.

Contents

| | |
|--|----|
| Preface | 2 |
| How Soil Surveys Are Made | 5 |
| Soil Map | 8 |
| Soil Map..... | 9 |
| Legend..... | 10 |
| Map Unit Legend..... | 11 |
| Map Unit Descriptions..... | 11 |
| Licking County, Ohio..... | 13 |
| Cen1C2—Centerburg silt loam, 6 to 12 percent slopes, eroded..... | 13 |
| GfB—Glenford silt loam, 2 to 6 percent slopes..... | 14 |
| Lu—Luray silty clay loam..... | 16 |
| OcA—Ockley silt loam, Southern Ohio Till Plain, 0 to 2 percent slopes..... | 17 |
| OcB—Ockley silt loam, Southern Ohio Till Plain, 2 to 6 percent slopes..... | 18 |
| Sh—Shoals silt loam, 0 to 2 percent slopes, occasionally flooded..... | 20 |
| References | 22 |

How Soil Surveys Are Made

Soil surveys are made to provide information about the soils and miscellaneous areas in a specific area. They include a description of the soils and miscellaneous areas and their location on the landscape and tables that show soil properties and limitations affecting various uses. Soil scientists observed the steepness, length, and shape of the slopes; the general pattern of drainage; the kinds of crops and native plants; and the kinds of bedrock. They observed and described many soil profiles. A soil profile is the sequence of natural layers, or horizons, in a soil. The profile extends from the surface down into the unconsolidated material in which the soil formed or from the surface down to bedrock. The unconsolidated material is devoid of roots and other living organisms and has not been changed by other biological activity.

Currently, soils are mapped according to the boundaries of major land resource areas (MLRAs). MLRAs are geographically associated land resource units that share common characteristics related to physiography, geology, climate, water resources, soils, biological resources, and land uses (USDA, 2006). Soil survey areas typically consist of parts of one or more MLRA.

The soils and miscellaneous areas in a survey area occur in an orderly pattern that is related to the geology, landforms, relief, climate, and natural vegetation of the area. Each kind of soil and miscellaneous area is associated with a particular kind of landform or with a segment of the landform. By observing the soils and miscellaneous areas in the survey area and relating their position to specific segments of the landform, a soil scientist develops a concept, or model, of how they were formed. Thus, during mapping, this model enables the soil scientist to predict with a considerable degree of accuracy the kind of soil or miscellaneous area at a specific location on the landscape.

Commonly, individual soils on the landscape merge into one another as their characteristics gradually change. To construct an accurate soil map, however, soil scientists must determine the boundaries between the soils. They can observe only a limited number of soil profiles. Nevertheless, these observations, supplemented by an understanding of the soil-vegetation-landscape relationship, are sufficient to verify predictions of the kinds of soil in an area and to determine the boundaries.

Soil scientists recorded the characteristics of the soil profiles that they studied. They noted soil color, texture, size and shape of soil aggregates, kind and amount of rock fragments, distribution of plant roots, reaction, and other features that enable them to identify soils. After describing the soils in the survey area and determining their properties, the soil scientists assigned the soils to taxonomic classes (units). Taxonomic classes are concepts. Each taxonomic class has a set of soil characteristics with precisely defined limits. The classes are used as a basis for comparison to classify soils systematically. Soil taxonomy, the system of taxonomic classification used in the United States, is based mainly on the kind and character of soil properties and the arrangement of horizons within the profile. After the soil

Custom Soil Resource Report

scientists classified and named the soils in the survey area, they compared the individual soils with similar soils in the same taxonomic class in other areas so that they could confirm data and assemble additional data based on experience and research.

The objective of soil mapping is not to delineate pure map unit components; the objective is to separate the landscape into landforms or landform segments that have similar use and management requirements. Each map unit is defined by a unique combination of soil components and/or miscellaneous areas in predictable proportions. Some components may be highly contrasting to the other components of the map unit. The presence of minor components in a map unit in no way diminishes the usefulness or accuracy of the data. The delineation of such landforms and landform segments on the map provides sufficient information for the development of resource plans. If intensive use of small areas is planned, onsite investigation is needed to define and locate the soils and miscellaneous areas.

Soil scientists make many field observations in the process of producing a soil map. The frequency of observation is dependent upon several factors, including scale of mapping, intensity of mapping, design of map units, complexity of the landscape, and experience of the soil scientist. Observations are made to test and refine the soil-landscape model and predictions and to verify the classification of the soils at specific locations. Once the soil-landscape model is refined, a significantly smaller number of measurements of individual soil properties are made and recorded. These measurements may include field measurements, such as those for color, depth to bedrock, and texture, and laboratory measurements, such as those for content of sand, silt, clay, salt, and other components. Properties of each soil typically vary from one point to another across the landscape.

Observations for map unit components are aggregated to develop ranges of characteristics for the components. The aggregated values are presented. Direct measurements do not exist for every property presented for every map unit component. Values for some properties are estimated from combinations of other properties.

While a soil survey is in progress, samples of some of the soils in the area generally are collected for laboratory analyses and for engineering tests. Soil scientists interpret the data from these analyses and tests as well as the field-observed characteristics and the soil properties to determine the expected behavior of the soils under different uses. Interpretations for all of the soils are field tested through observation of the soils in different uses and under different levels of management. Some interpretations are modified to fit local conditions, and some new interpretations are developed to meet local needs. Data are assembled from other sources, such as research information, production records, and field experience of specialists. For example, data on crop yields under defined levels of management are assembled from farm records and from field or plot experiments on the same kinds of soil.

Predictions about soil behavior are based not only on soil properties but also on such variables as climate and biological activity. Soil conditions are predictable over long periods of time, but they are not predictable from year to year. For example, soil scientists can predict with a fairly high degree of accuracy that a given soil will have a high water table within certain depths in most years, but they cannot predict that a high water table will always be at a specific level in the soil on a specific date.

After soil scientists located and identified the significant natural bodies of soil in the survey area, they drew the boundaries of these bodies on aerial photographs and

Custom Soil Resource Report

identified each as a specific map unit. Aerial photographs show trees, buildings, fields, roads, and rivers, all of which help in locating boundaries accurately.

Soil Map

The soil map section includes the soil map for the defined area of interest, a list of soil map units on the map and extent of each map unit, and cartographic symbols displayed on the map. Also presented are various metadata about data used to produce the map, and a description of each soil map unit.

Custom Soil Resource Report Soil Map

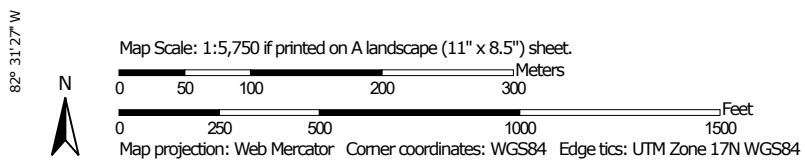
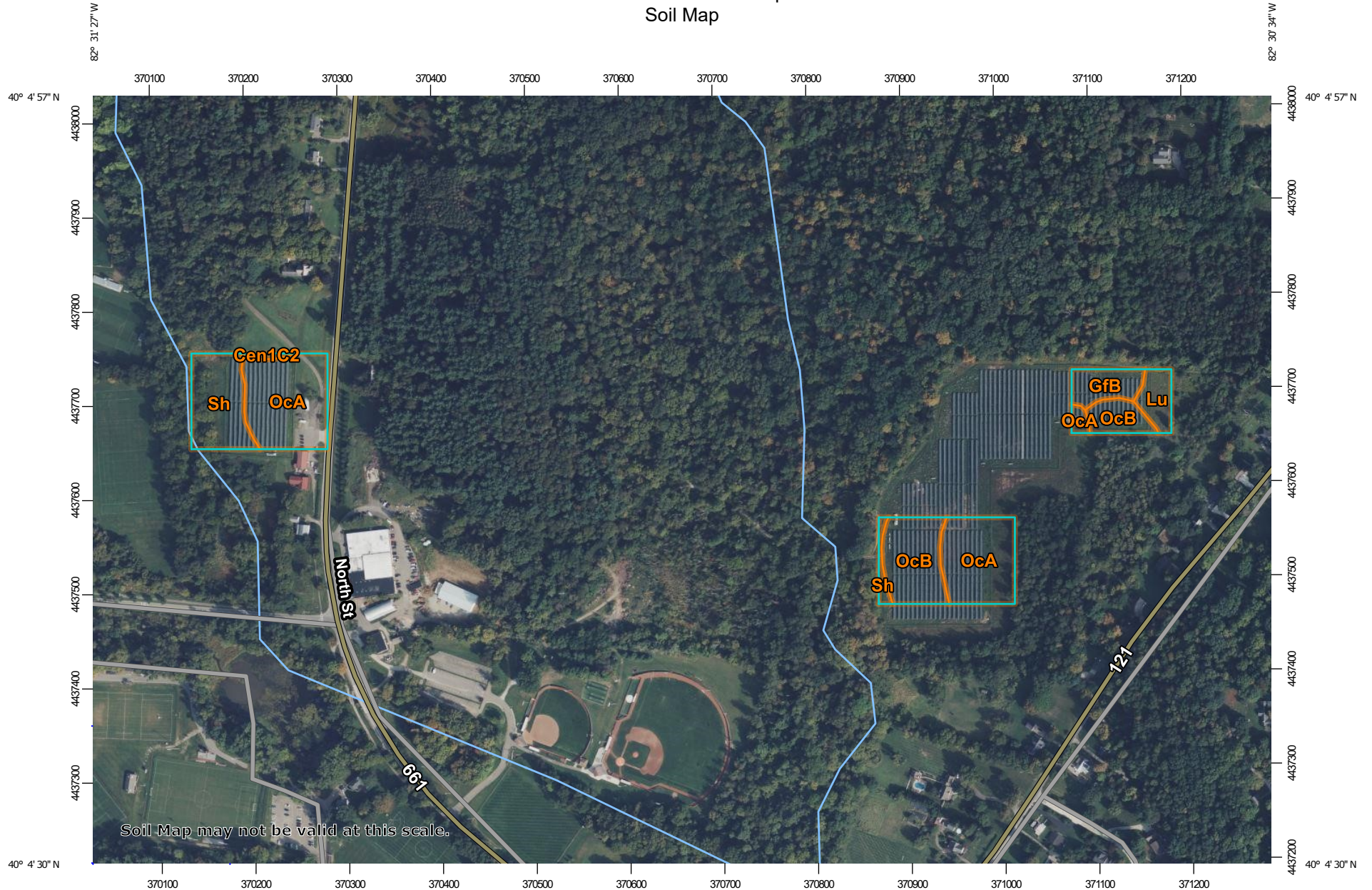

MAP LEGEND

Area of Interest (AOI)

 Area of Interest (AOI)

Soils

 Soil Map Unit Polygons

 Soil Map Unit Lines

 Soil Map Unit Points

Special Point Features

 Blowout

 Borrow Pit

 Clay Spot

 Closed Depression

 Gravel Pit

 Gravelly Spot

 Landfill

 Lava Flow

 Marsh or swamp

 Mine or Quarry

 Miscellaneous Water

 Perennial Water

 Rock Outcrop

 Saline Spot

 Sandy Spot

 Severely Eroded Spot

 Sinkhole

 Slide or Slip

 Sodic Spot

 Spoil Area

 Stony Spot

 Very Stony Spot

 Wet Spot

 Other

 Special Line Features

Water Features

 Streams and Canals

Transportation

 Rails

 Interstate Highways

 US Routes

 Major Roads

 Local Roads

Background

 Aerial Photography

MAP INFORMATION

The soil surveys that comprise your AOI were mapped at 1:15,800.

Warning: Soil Map may not be valid at this scale.

Enlargement of maps beyond the scale of mapping can cause misunderstanding of the detail of mapping and accuracy of soil line placement. The maps do not show the small areas of contrasting soils that could have been shown at a more detailed scale.

Please rely on the bar scale on each map sheet for map measurements.

Source of Map: Natural Resources Conservation Service
 Web Soil Survey URL:
 Coordinate System: Web Mercator (EPSG:3857)

Maps from the Web Soil Survey are based on the Web Mercator projection, which preserves direction and shape but distorts distance and area. A projection that preserves area, such as the Albers equal-area conic projection, should be used if more accurate calculations of distance or area are required.

This product is generated from the USDA-NRCS certified data as of the version date(s) listed below.

Soil Survey Area: Licking County, Ohio
 Survey Area Data: Version 20, Sep 9, 2022

Soil map units are labeled (as space allows) for map scales 1:50,000 or larger.

Date(s) aerial images were photographed: Apr 1, 2020—Oct 1, 2020

The orthophoto or other base map on which the soil lines were compiled and digitized probably differs from the background imagery displayed on these maps. As a result, some minor shifting of map unit boundaries may be evident.

Map Unit Legend

| Map Unit Symbol | Map Unit Name | Acres in AOI | Percent of AOI |
|------------------------------------|---|--------------|----------------|
| Cen1C2 | Centerburg silt loam, 6 to 12 percent slopes, eroded | 0.1 | 0.7% |
| GfB | Glenford silt loam, 2 to 6 percent slopes | 0.6 | 7.3% |
| Lu | Luray silty clay loam | 0.5 | 5.6% |
| OcA | Ockley silt loam, Southern Ohio Till Plain, 0 to 2 percent slopes | 4.0 | 45.5% |
| OcB | Ockley silt loam, Southern Ohio Till Plain, 2 to 6 percent slopes | 2.0 | 22.3% |
| Sh | Shoals silt loam, 0 to 2 percent slopes, occasionally flooded | 1.6 | 18.5% |
| Totals for Area of Interest | | 8.8 | 100.0% |

Map Unit Descriptions

The map units delineated on the detailed soil maps in a soil survey represent the soils or miscellaneous areas in the survey area. The map unit descriptions, along with the maps, can be used to determine the composition and properties of a unit.

A map unit delineation on a soil map represents an area dominated by one or more major kinds of soil or miscellaneous areas. A map unit is identified and named according to the taxonomic classification of the dominant soils. Within a taxonomic class there are precisely defined limits for the properties of the soils. On the landscape, however, the soils are natural phenomena, and they have the characteristic variability of all natural phenomena. Thus, the range of some observed properties may extend beyond the limits defined for a taxonomic class. Areas of soils of a single taxonomic class rarely, if ever, can be mapped without including areas of other taxonomic classes. Consequently, every map unit is made up of the soils or miscellaneous areas for which it is named and some minor components that belong to taxonomic classes other than those of the major soils.

Most minor soils have properties similar to those of the dominant soil or soils in the map unit, and thus they do not affect use and management. These are called noncontrasting, or similar, components. They may or may not be mentioned in a particular map unit description. Other minor components, however, have properties and behavioral characteristics divergent enough to affect use or to require different management. These are called contrasting, or dissimilar, components. They generally are in small areas and could not be mapped separately because of the scale used. Some small areas of strongly contrasting soils or miscellaneous areas are identified by a special symbol on the maps. If included in the database for a given area, the contrasting minor components are identified in the map unit descriptions along with some characteristics of each. A few areas of minor components may not have been observed, and consequently they are not

Custom Soil Resource Report

mentioned in the descriptions, especially where the pattern was so complex that it was impractical to make enough observations to identify all the soils and miscellaneous areas on the landscape.

The presence of minor components in a map unit in no way diminishes the usefulness or accuracy of the data. The objective of mapping is not to delineate pure taxonomic classes but rather to separate the landscape into landforms or landform segments that have similar use and management requirements. The delineation of such segments on the map provides sufficient information for the development of resource plans. If intensive use of small areas is planned, however, onsite investigation is needed to define and locate the soils and miscellaneous areas.

An identifying symbol precedes the map unit name in the map unit descriptions. Each description includes general facts about the unit and gives important soil properties and qualities.

Soils that have profiles that are almost alike make up a *soil series*. Except for differences in texture of the surface layer, all the soils of a series have major horizons that are similar in composition, thickness, and arrangement.

Soils of one series can differ in texture of the surface layer, slope, stoniness, salinity, degree of erosion, and other characteristics that affect their use. On the basis of such differences, a soil series is divided into *soil phases*. Most of the areas shown on the detailed soil maps are phases of soil series. The name of a soil phase commonly indicates a feature that affects use or management. For example, Alpha silt loam, 0 to 2 percent slopes, is a phase of the Alpha series.

Some map units are made up of two or more major soils or miscellaneous areas. These map units are complexes, associations, or undifferentiated groups.

A *complex* consists of two or more soils or miscellaneous areas in such an intricate pattern or in such small areas that they cannot be shown separately on the maps. The pattern and proportion of the soils or miscellaneous areas are somewhat similar in all areas. Alpha-Beta complex, 0 to 6 percent slopes, is an example.

An *association* is made up of two or more geographically associated soils or miscellaneous areas that are shown as one unit on the maps. Because of present or anticipated uses of the map units in the survey area, it was not considered practical or necessary to map the soils or miscellaneous areas separately. The pattern and relative proportion of the soils or miscellaneous areas are somewhat similar. Alpha-Beta association, 0 to 2 percent slopes, is an example.

An *undifferentiated group* is made up of two or more soils or miscellaneous areas that could be mapped individually but are mapped as one unit because similar interpretations can be made for use and management. The pattern and proportion of the soils or miscellaneous areas in a mapped area are not uniform. An area can be made up of only one of the major soils or miscellaneous areas, or it can be made up of all of them. Alpha and Beta soils, 0 to 2 percent slopes, is an example.

Some surveys include *miscellaneous areas*. Such areas have little or no soil material and support little or no vegetation. Rock outcrop is an example.

Licking County, Ohio

Cen1C2—Centerburg silt loam, 6 to 12 percent slopes, eroded

Map Unit Setting

National map unit symbol: 2wp1y
Elevation: 780 to 1,400 feet
Mean annual precipitation: 36 to 42 inches
Mean annual air temperature: 48 to 54 degrees F
Frost-free period: 145 to 170 days
Farmland classification: Farmland of local importance

Map Unit Composition

Centerburg, eroded, and similar soils: 85 percent
Minor components: 15 percent
Estimates are based on observations, descriptions, and transects of the mapunit.

Description of Centerburg, Eroded

Setting

Landform: End moraines, ground moraines
Landform position (two-dimensional): Shoulder, backslope
Landform position (three-dimensional): Crest, side slope
Down-slope shape: Convex
Across-slope shape: Convex, linear
Parent material: Wisconsin loamy till derived from sandstone and shale

Typical profile

Ap - 0 to 7 inches: silt loam
Bt1 - 7 to 18 inches: silty clay loam
Bt2 - 18 to 31 inches: clay loam
BC - 31 to 36 inches: clay loam
C - 36 to 79 inches: loam

Properties and qualities

Slope: 6 to 12 percent
Depth to restrictive feature: More than 80 inches
Drainage class: Moderately well drained
Runoff class: Medium
Capacity of the most limiting layer to transmit water (Ksat): Moderately high (0.20 to 0.60 in/hr)
Depth to water table: About 12 to 24 inches
Frequency of flooding: None
Frequency of ponding: None
Calcium carbonate, maximum content: 22 percent
Maximum salinity: Nonsaline to very slightly saline (0.0 to 2.0 mmhos/cm)
Available water supply, 0 to 60 inches: Moderate (about 7.9 inches)

Interpretive groups

Land capability classification (irrigated): None specified
Land capability classification (nonirrigated): 2e
Hydrologic Soil Group: C/D
Ecological site: F111XE503OH - Till Ridge
Hydric soil rating: No

Minor Components

Amanda, severely eroded

Percent of map unit: 6 percent
Landform: End moraines, ground moraines
Landform position (two-dimensional): Shoulder, backslope
Landform position (three-dimensional): Side slope
Down-slope shape: Convex
Across-slope shape: Linear
Ecological site: F111XE503OH - Till Ridge
Hydric soil rating: No

Bennington

Percent of map unit: 5 percent
Landform: End moraines, ground moraines
Landform position (two-dimensional): Footslope, backslope
Landform position (three-dimensional): Interfluve
Down-slope shape: Concave, linear
Across-slope shape: Linear
Ecological site: F111XE502OH - Wet Till Ridge
Hydric soil rating: No

Condit

Percent of map unit: 4 percent
Landform: Depressions, drainageways
Landform position (two-dimensional): Toeslope
Landform position (three-dimensional): Base slope
Down-slope shape: Concave, linear
Across-slope shape: Concave
Ecological site: F111XE501OH - Till Depression
Hydric soil rating: Yes

GfB—Glenford silt loam, 2 to 6 percent slopes

Map Unit Setting

National map unit symbol: 5qz4
Elevation: 690 to 1,110 feet
Mean annual precipitation: 31 to 40 inches
Mean annual air temperature: 46 to 55 degrees F
Frost-free period: 130 to 193 days
Farmland classification: All areas are prime farmland

Map Unit Composition

Glenford and similar soils: 90 percent
Minor components: 10 percent
Estimates are based on observations, descriptions, and transects of the mapunit.

Description of Glenford

Setting

Landform: Hills, knolls on terraces, knolls on lake plains
Landform position (two-dimensional): Footslope, summit
Landform position (three-dimensional): Base slope, tread, rise
Down-slope shape: Concave, convex
Across-slope shape: Linear, convex
Parent material: Silty glaciolacustrine deposits derived from interbedded sedimentary rock

Typical profile

H1 - 0 to 9 inches: silt loam
H2 - 9 to 39 inches: silt loam
H3 - 39 to 45 inches: silt loam
H4 - 45 to 60 inches: silt loam

Properties and qualities

Slope: 2 to 6 percent
Depth to restrictive feature: More than 80 inches
Drainage class: Moderately well drained
Runoff class: Medium
Capacity of the most limiting layer to transmit water (Ksat): Moderately high (0.20 to 0.60 in/hr)
Depth to water table: About 24 to 42 inches
Frequency of flooding: None
Frequency of ponding: None
Calcium carbonate, maximum content: 5 percent
Available water supply, 0 to 60 inches: High (about 9.5 inches)

Interpretive groups

Land capability classification (irrigated): None specified
Land capability classification (nonirrigated): 2e
Hydrologic Soil Group: C
Forage suitability group: Unnamed (G114AYA-6OH)
Other vegetative classification: Unnamed (G114AYA-6OH)
Hydric soil rating: No

Minor Components

Luray

Percent of map unit: 5 percent
Landform: Depressions
Hydric soil rating: Yes

Sebring

Percent of map unit: 5 percent
Landform: Draws
Hydric soil rating: Yes

Lu—Luray silty clay loam

Map Unit Setting

National map unit symbol: 5qzm
Elevation: 890 to 1,120 feet
Mean annual precipitation: 34 to 40 inches
Mean annual air temperature: 50 to 54 degrees F
Frost-free period: 146 to 166 days
Farmland classification: Prime farmland if drained

Map Unit Composition

Luray and similar soils: 100 percent
Estimates are based on observations, descriptions, and transects of the mapunit.

Description of Luray

Setting

Landform: Depressions on terraces, depressions on lake plains, flats on terraces, flats on lake plains
Landform position (three-dimensional): Dip, talf
Down-slope shape: Concave, linear
Across-slope shape: Concave, linear
Parent material: Silty lacustrine deposits derived from interbedded sedimentary rock

Typical profile

H1 - 0 to 12 inches: silty clay loam
H2 - 12 to 40 inches: silty clay loam
H3 - 40 to 60 inches: stratified fine sandy loam to silty clay loam

Properties and qualities

Slope: 0 to 2 percent
Depth to restrictive feature: More than 80 inches
Drainage class: Very poorly drained
Runoff class: Negligible
Capacity of the most limiting layer to transmit water (Ksat): Moderately high (0.20 to 0.60 in/hr)
Depth to water table: About 0 to 12 inches
Frequency of flooding: None
Frequency of ponding: Frequent
Calcium carbonate, maximum content: 5 percent
Available water supply, 0 to 60 inches: High (about 11.4 inches)

Interpretive groups

Land capability classification (irrigated): None specified
Land capability classification (nonirrigated): 2w
Hydrologic Soil Group: C/D
Hydric soil rating: Yes

OcA—Ockley silt loam, Southern Ohio Till Plain, 0 to 2 percent slopes

Map Unit Setting

National map unit symbol: 2t4lh
Elevation: 400 to 1,300 feet
Mean annual precipitation: 35 to 45 inches
Mean annual air temperature: 48 to 55 degrees F
Frost-free period: 125 to 190 days
Farmland classification: All areas are prime farmland

Map Unit Composition

Ockley and similar soils: 85 percent
Minor components: 15 percent
Estimates are based on observations, descriptions, and transects of the mapunit.

Description of Ockley

Setting

Landform: Outwash terraces
Landform position (two-dimensional): Summit
Landform position (three-dimensional): Tread
Down-slope shape: Linear
Across-slope shape: Linear
Parent material: Loess over loamy outwash over stratified sandy and gravelly outwash

Typical profile

Ap - 0 to 9 inches: silt loam
Bt1 - 9 to 20 inches: silty clay loam
2Bt2 - 20 to 64 inches: gravelly clay loam
3C - 64 to 79 inches: gravelly loamy sand

Properties and qualities

Slope: 0 to 2 percent
Depth to restrictive feature: 40 to 70 inches to strongly contrasting textural stratification
Drainage class: Well drained
Runoff class: Low
Capacity of the most limiting layer to transmit water (Ksat): Moderately high to high (0.60 to 2.00 in/hr)
Depth to water table: More than 80 inches
Frequency of flooding: None
Frequency of ponding: None
Calcium carbonate, maximum content: 50 percent
Maximum salinity: Nonsaline to very slightly saline (0.0 to 2.0 mmhos/cm)
Available water supply, 0 to 60 inches: Moderate (about 8.9 inches)

Interpretive groups

Land capability classification (irrigated): None specified
Land capability classification (nonirrigated): 1
Hydrologic Soil Group: B

Custom Soil Resource Report

Ecological site: F111XA015IN - Dry Outwash Upland
Hydric soil rating: No

Minor Components

Fox

Percent of map unit: 5 percent
Landform: Outwash plains, terraces
Landform position (two-dimensional): Summit
Landform position (three-dimensional): Tread, talf
Down-slope shape: Convex
Across-slope shape: Linear
Ecological site: F111XA015IN - Dry Outwash Upland
Hydric soil rating: No

Sleeth

Percent of map unit: 5 percent
Landform: Stream terraces, outwash terraces
Landform position (two-dimensional): Shoulder, backslope
Landform position (three-dimensional): Tread
Down-slope shape: Linear
Across-slope shape: Linear
Ecological site: F111XA014IN - Outwash Upland
Hydric soil rating: No

Eldean

Percent of map unit: 5 percent
Landform: Outwash terraces
Landform position (two-dimensional): Shoulder, backslope
Landform position (three-dimensional): Tread
Down-slope shape: Linear
Across-slope shape: Linear
Ecological site: F111XA015IN - Dry Outwash Upland
Hydric soil rating: No

OcB—Ockley silt loam, Southern Ohio Till Plain, 2 to 6 percent slopes

Map Unit Setting

National map unit symbol: 2t4ln
Elevation: 400 to 1,300 feet
Mean annual precipitation: 37 to 46 inches
Mean annual air temperature: 48 to 55 degrees F
Frost-free period: 155 to 180 days
Farmland classification: All areas are prime farmland

Map Unit Composition

Ockley and similar soils: 85 percent
Minor components: 15 percent
Estimates are based on observations, descriptions, and transects of the mapunit.

Description of Ockley

Setting

Landform: Outwash terraces
Landform position (two-dimensional): Shoulder
Landform position (three-dimensional): Tread
Down-slope shape: Linear
Across-slope shape: Linear
Parent material: Loess over loamy outwash over sandy and gravelly outwash

Typical profile

Ap - 0 to 10 inches: silt loam
2Bt1 - 10 to 41 inches: clay loam
2Bt2 - 41 to 66 inches: gravelly clay loam
3C - 66 to 79 inches: gravelly loamy coarse sand

Properties and qualities

Slope: 2 to 6 percent
Depth to restrictive feature: 40 to 70 inches to strongly contrasting textural stratification
Drainage class: Well drained
Runoff class: Low
Capacity of the most limiting layer to transmit water (Ksat): Moderately high to high (0.60 to 2.00 in/hr)
Depth to water table: More than 80 inches
Frequency of flooding: None
Frequency of ponding: None
Calcium carbonate, maximum content: 50 percent
Maximum salinity: Nonsaline to very slightly saline (0.0 to 2.0 mmhos/cm)
Available water supply, 0 to 60 inches: High (about 9.7 inches)

Interpretive groups

Land capability classification (irrigated): None specified
Land capability classification (nonirrigated): 2e
Hydrologic Soil Group: B
Ecological site: F111XA015IN - Dry Outwash Upland, F111XD018IN - Dry Outwash Upland
Hydric soil rating: No

Minor Components

Sleeth

Percent of map unit: 5 percent
Landform: Stream terraces, outwash terraces
Landform position (two-dimensional): Shoulder, backslope
Landform position (three-dimensional): Tread
Down-slope shape: Linear
Across-slope shape: Linear
Ecological site: F111XA014IN - Outwash Upland
Hydric soil rating: No

Eldean

Percent of map unit: 5 percent
Landform: Outwash terraces
Landform position (two-dimensional): Shoulder, backslope
Landform position (three-dimensional): Tread

Custom Soil Resource Report

Down-slope shape: Linear
Across-slope shape: Linear
Ecological site: F111XA015IN - Dry Outwash Upland
Hydric soil rating: No

Fox

Percent of map unit: 5 percent
Landform: Outwash plains, terraces
Landform position (two-dimensional): Summit
Landform position (three-dimensional): Tread, talf
Down-slope shape: Convex
Across-slope shape: Linear
Ecological site: F111XA015IN - Dry Outwash Upland
Hydric soil rating: No

Sh—Shoals silt loam, 0 to 2 percent slopes, occasionally flooded

Map Unit Setting

National map unit symbol: 2t6lp
Elevation: 340 to 1,000 feet
Mean annual precipitation: 34 to 42 inches
Mean annual air temperature: 48 to 55 degrees F
Frost-free period: 140 to 180 days
Farmland classification: Prime farmland if drained

Map Unit Composition

Shoals and similar soils: 85 percent
Minor components: 15 percent
Estimates are based on observations, descriptions, and transects of the mapunit.

Description of Shoals

Setting

Landform: Flood plains
Landform position (three-dimensional): Dip
Down-slope shape: Linear
Across-slope shape: Linear
Parent material: Loamy alluvium

Typical profile

Ap - 0 to 10 inches: silt loam
B - 10 to 42 inches: silt loam
C - 42 to 79 inches: stratified sandy loam to silt loam

Properties and qualities

Slope: 0 to 2 percent
Depth to restrictive feature: More than 80 inches
Drainage class: Somewhat poorly drained
Runoff class: Low
Capacity of the most limiting layer to transmit water (Ksat): Moderately high to high
(0.60 to 2.00 in/hr)

Custom Soil Resource Report

Depth to water table: About 6 to 18 inches
Frequency of flooding: NoneOccasional
Frequency of ponding: None
Calcium carbonate, maximum content: 22 percent
Available water supply, 0 to 60 inches: High (about 10.0 inches)

Interpretive groups

Land capability classification (irrigated): None specified
Land capability classification (nonirrigated): 2w
Hydrologic Soil Group: B/D
Ecological site: F111XB203IN - Wet Alluvium Forest, F111XE203OH - Wet Alluvium Forest
Hydric soil rating: No

Minor Components

Sloan

Percent of map unit: 8 percent
Landform: Flood plains
Landform position (three-dimensional): Dip
Down-slope shape: Linear
Across-slope shape: Linear
Ecological site: F111XB201IN - Wet Alluvium Floodplain
Hydric soil rating: Yes

Eel

Percent of map unit: 7 percent
Landform: Flood plains
Landform position (three-dimensional): Rise
Down-slope shape: Linear
Across-slope shape: Linear
Ecological site: F111XB204IN - Dry Alluvium Forest
Hydric soil rating: No

References

- American Association of State Highway and Transportation Officials (AASHTO). 2004. Standard specifications for transportation materials and methods of sampling and testing. 24th edition.
- American Society for Testing and Materials (ASTM). 2005. Standard classification of soils for engineering purposes. ASTM Standard D2487-00.
- Cowardin, L.M., V. Carter, F.C. Golet, and E.T. LaRoe. 1979. Classification of wetlands and deep-water habitats of the United States. U.S. Fish and Wildlife Service FWS/OBS-79/31.
- Federal Register. July 13, 1994. Changes in hydric soils of the United States.
- Federal Register. September 18, 2002. Hydric soils of the United States.
- Hurt, G.W., and L.M. Vasilas, editors. Version 6.0, 2006. Field indicators of hydric soils in the United States.
- National Research Council. 1995. Wetlands: Characteristics and boundaries.
- Soil Survey Division Staff. 1993. Soil survey manual. Soil Conservation Service. U.S. Department of Agriculture Handbook 18. http://www.nrcs.usda.gov/wps/portal/nrcs/detail/national/soils/?cid=nrcs142p2_054262
- Soil Survey Staff. 1999. Soil taxonomy: A basic system of soil classification for making and interpreting soil surveys. 2nd edition. Natural Resources Conservation Service, U.S. Department of Agriculture Handbook 436. http://www.nrcs.usda.gov/wps/portal/nrcs/detail/national/soils/?cid=nrcs142p2_053577
- Soil Survey Staff. 2010. Keys to soil taxonomy. 11th edition. U.S. Department of Agriculture, Natural Resources Conservation Service. http://www.nrcs.usda.gov/wps/portal/nrcs/detail/national/soils/?cid=nrcs142p2_053580
- Tiner, R.W., Jr. 1985. Wetlands of Delaware. U.S. Fish and Wildlife Service and Delaware Department of Natural Resources and Environmental Control, Wetlands Section.
- United States Army Corps of Engineers, Environmental Laboratory. 1987. Corps of Engineers wetlands delineation manual. Waterways Experiment Station Technical Report Y-87-1.
- United States Department of Agriculture, Natural Resources Conservation Service. National forestry manual. http://www.nrcs.usda.gov/wps/portal/nrcs/detail/soils/home/?cid=nrcs142p2_053374
- United States Department of Agriculture, Natural Resources Conservation Service. National range and pasture handbook. <http://www.nrcs.usda.gov/wps/portal/nrcs/detail/national/landuse/rangepasture/?cid=stelprdb1043084>

Custom Soil Resource Report

United States Department of Agriculture, Natural Resources Conservation Service. National soil survey handbook, title 430-VI. http://www.nrcs.usda.gov/wps/portal/nrcs/detail/soils/scientists/?cid=nrcs142p2_054242

United States Department of Agriculture, Natural Resources Conservation Service. 2006. Land resource regions and major land resource areas of the United States, the Caribbean, and the Pacific Basin. U.S. Department of Agriculture Handbook 296. http://www.nrcs.usda.gov/wps/portal/nrcs/detail/national/soils/?cid=nrcs142p2_053624

United States Department of Agriculture, Soil Conservation Service. 1961. Land capability classification. U.S. Department of Agriculture Handbook 210. http://www.nrcs.usda.gov/Internet/FSE_DOCUMENTS/nrcs142p2_052290.pdf

ATTACHMENT 2

**ASTM Standard Test Methods for
In-Place Density and Water Content of Soil and Soil Aggregate by
Nuclear Methods (D6938)
and
Infiltration Rate of Soils in Field Using Double-Ring Infiltrometer
(D3385)**



Standard Test Methods for In-Place Density and Water Content of Soil and Soil- Aggregate by Nuclear Methods (Shallow Depth)¹

This standard is issued under the fixed designation D 6938; the number immediately following the designation indicates the year of original adoption or, in the case of revision, the year of last revision. A number in parentheses indicates the year of last reappraisal. A superscript epsilon (ϵ) indicates an editorial change since the last revision or reappraisal.

1. Scope*

1.1 This test method describes the procedures for measuring in-place density and moisture of soil and soil-aggregate by use of nuclear equipment. The density of the material may be measured by direct transmission, backscatter, or backscatter/air-gap ratio methods. Measurements for water (moisture) content are taken at the surface in backscatter mode regardless of the mode being used for density. It is the intent of this subcommittee that this standard replaces D2922 and D3017.

1.1.1 For limitations see Section 5 on Interferences.

1.2 The total or wet density of soil and soil-aggregate is measured by the attenuation of gamma radiation where, in direct transmission, the source is placed at a known depth up to 300 mm (12 in.) and the detector (s) remains on the surface (some gauges may reverse this orientation); or in backscatter or backscatter/air-gap the source and detector (s) both remain on the surface.

1.2.1 The density of the test sample in mass per unit volume is calculated by comparing the detected rate of gamma radiation with previously established calibration data.

1.2.2 The dry density of the test sample is obtained by subtracting the water mass per unit volume from the test sample wet density (Section 11). Most gauges display this value directly.

1.3 The gauge is calibrated to read the water mass per unit volume of soil or soil-aggregate. When divided by the density of water, and then multiplied by 100, the water mass per unit volume is equivalent to the volumetric water content. The water mass per unit volume is determined by the thermalizing or slowing of fast neutrons by hydrogen, a component of water. The neutron source and the thermal neutron detector are both located at the surface of the material being tested. The water content most prevalent in engineering and construction activities is known as the gravimetric water content, w , and is the ratio of the mass of the water in pore spaces to the total mass of solids, expressed as a percentage.

1.4 Two alternative procedures are provided.

1.4.1 *Procedure A* describes the direct transmission method in which the gamma source rod extends through the base of the gauge into a pre-formed hole to a desired depth. The direct transmission is the preferred method.

1.4.2 *Procedure B* involves the use of a dedicated backscatter gauge or the source rod in the backscatter position. This places the gamma and neutron sources and the detectors in the same plane.

1.5 *SI Units*—The values stated in SI units are to be regarded as the standard. The values in inch-pound units (ft – lb units) are provided for information only.

1.6 All observed and calculated values shall conform to the guide for significant digits and rounding established in Practice D 6026.

1.6.1 The procedures used to specify how data are collected, recorded, and calculated in this standard are regarded as the industry standard. In addition, they are representative of the significant digits that should generally be retained. The procedures used do not consider material variation, purpose for obtaining the data, special purpose studies, or any considerations for the user's objectives; and it is common practice to increase or reduce significant digits of reported data to be commensurate with these considerations. It is beyond the scope of this standard to consider significant digits used in analysis methods for engineering design.

1.7 *This standard does not purport to address all of the safety concerns, if any, associated with its use. It is the responsibility of the user of this standard to establish appropriate safety and health practices and determine the applicability of regulatory limitations prior to use.*

2. Referenced Documents

2.1 *ASTM Standards:*²

D 653 Terminology Relating to Soil, Rock, and Contained Fluids

D 698 Test Methods for Laboratory Compaction Characteristics of Soil Using Standard Effort (12,400 ft-lbf/ft³(600 kN-m/m³))

¹ This test method is under the jurisdiction of ASTM Committee D18 on Soil and Rock and is the direct responsibility of Subcommittee D18.08 Special and Construction Control Tests.

Current edition approved May 1, 2007. Published June 2007. Originally approved in 2006. Last previous edition approved in 2006 as D 6938–06¹.

² For referenced ASTM standards, visit the ASTM website, www.astm.org, or contact ASTM Customer Service at service@astm.org. For *Annual Book of ASTM Standards* volume information, refer to the standard's Document Summary page on the ASTM website.

*A Summary of Changes section appears at the end of this standard.

- D 1556** Test Method for Density and Unit Weight of Soil in Place by the Sand-Cone Method
- D 1557** Test Methods for Laboratory Compaction Characteristics of Soil Using Modified Effort (56,000 ft-lbf/ft³ (2,700 kN-m/m³))
- D 2167** Test Method for Density and Unit Weight of Soil in Place by the Rubber Balloon Method
- D 2487** Practice for Classification of Soils for Engineering Purposes (Unified Soil Classification System)
- D 2488** Practice for Description and Identification of Soils (Visual-Manual Procedure)
- D 2216** Test Methods for Laboratory Determination of Water (Moisture) Content of Soil and Rock by Mass
- D 2937** Test Method for Density of Soil in Place by the Drive-Cylinder Method
- D 3740** Practice for Minimum Requirements for Agencies Engaged in the Testing and/or Inspection of Soil and Rock as Used in Engineering Design and Construction
- D 4253** Test Methods for Maximum Index Density and Unit Weight of Soils Using a Vibratory Table
- D 4254** Test Methods for Minimum Index Density and Unit Weight of Soils and Calculation of Relative Density
- D 4643** Test Method for Determination of Water (Moisture) Content of Soil by the Microwave Oven Method
- D 4718** Practice for Correction of Unit Weight and Water Content for Soils Containing Oversize Particles
- D 4944** Test Method for Field Determination of Water (Moisture) Content of Soil by the Calcium Carbide Gas Pressure Tester
- D 4959** Test Method for Determination of Water (Moisture) Content of Soil By Direct Heating
- D 6026** Practice for Using Significant Digits in Geotechnical Data
- D 7013** Guide for Nuclear Surface Moisture and Density Gauge Calibration Facility Setup

3. Terminology

3.1 Definitions - See Terminology **D 653** for general definitions.

3.2 *Definitions of Terms Specific to This Standard:*

3.2.1 *Nuclear Gauge*—A device containing one or more radioactive sources used to measure certain properties of soil and soil-aggregates.

3.2.2 *In-place Density*—The total mass (solids plus water) per total volume of soil or soil-aggregates measured in place.

3.2.3 *Gamma (Radiation) Source*—A sealed source of radioactive material that emits gamma radiation as it decays.

3.2.4 *Neutron (Radiation) Source*—A sealed source of radioactive material that emits neutron radiation as it decays.

3.2.5 *Compton Scattering*—The interaction between a gamma ray (photon) and an orbital electron where the gamma ray loses energy and rebounds in a different direction.

3.2.6 *Detector*—A device to detect and measure radiation.

3.2.7 *Source Rod*—A metal rod attached to a nuclear gauge in which a radioactive source or a detector is housed. The rod can be lowered to specified depths for testing.

3.2.8 *Thermalization*—The process of “slowing down” fast neutrons by collisions with light-weight atoms, such as hydrogen.

3.2.9 *Water Content*—The ratio of the mass of water contained in the pore spaces of soil or soil-aggregate, to the solid mass of particles in that material, expressed as a percentage (*this is sometimes referred to in some scientific fields as gravimetric water content to differentiate it from volumetric water content*).

3.2.10 *Volumetric Water Content*—the volume of water as a percent of the total volume of soil or rock material.

3.2.11 *Test Count, N*—The measured output of a detector for a specific type of radiation for a given test.

3.2.12 *Prepared Blocks*—Blocks prepared of soil, solid rock, concrete, and engineered materials, that have characteristics of various degrees of reproducible uniformity.

4. Significance and Use

4.1 The test method described is useful as a rapid, nondestructive technique for in-place measurements of wet density and water content of soil and soil-aggregate and the determination of dry density.

4.2 The test method is used for quality control and acceptance testing of compacted soil and soil-aggregate mixtures as used in construction and also for research and development. The non-destructive nature allows repetitive measurements at a single test location and statistical analysis of the results.

4.3 *Density*—The fundamental assumptions inherent in the methods are that Compton scattering is the dominant interaction and that the material is homogeneous.

4.4 *Water Content*—The fundamental assumptions inherent in the test method are that the hydrogen ions present in the soil or soil-aggregate are in the form of water as defined by the water content derived from Test Methods **D 2216**, and that the material is homogeneous. (See **5.2**)

NOTE 1—The quality of the result produced by this standard test method is dependent on the competence of the personnel performing it, and the suitability of the equipment and facilities used. Agencies that meet the criteria of Practice **D 3740** are generally considered capable of competent and objective testing/sampling/inspection, and the like. Users of this standard are cautioned that compliance with Practice **D 3740** does not in itself assure reliable results. Reliable results depend on many factors; Practice **D 3740** provides a means of evaluating some of those factors.

5. Interferences

5.1 *In-Place Density Interferences*

5.1.1 Measurements may be affected by the chemical composition of the material being tested.

5.1.2 Measurements may be affected by non-homogeneous soils and surface texture (see **10.2**).

5.1.3 Measurements in the Backscatter Mode are influenced more by the density and water content of the material in close proximity to the surface.

5.1.4 Measurements in the Direct Transmission mode are an average of the density from the bottom of the probe in the ground back up to the surface of the gauge.

5.1.5 Oversize particles or large voids in the source-detector path may cause higher or lower density measurements. Where lack of uniformity in the soil due to layering, aggregate or voids is suspected, the test site should be excavated and

visually examined to determine if the test material is representative of the in-situ material in general and if an oversize correction is required in accordance with Practice D 4718.

5.1.6 The measured volume is approximately 0.0028 m³(0.10 ft³) for the Backscatter Mode and 0.0057 m³(0.20 ft³) for the Direct Transmission Mode when the test depth is 150 mm (6 in.). The actual measured volume is indeterminate and varies with the apparatus and the density of the material.

5.1.7 Other radioactive sources must not be within 9 m (30 ft.) of equipment in operation.

5.2 *In-Place Water (Moisture) Content Interferences*

5.2.1 The chemical composition of the material being tested can affect the measurement and adjustments may be necessary (see Section 10.6). Hydrogen in forms other than water and carbon will cause measurements in excess of the true value. Some chemical elements such as boron, chlorine, and cadmium will cause measurements lower than the true value.

5.2.2 The water content measured by this test method is not necessarily the average water content within the volume of the sample involved in the measurement. Since this measurement is by backscatter in all cases, the value is biased by the water content of the material closest to the surface. The volume of soil and soil-aggregate represented in the measurement is indeterminate and will vary with the water content of the material. In general, the greater the water content of the material, the smaller the volume involved in the measurement. Approximately 50 % of the typical measurement results from the water content of the upper 50 to 75 mm (2 to 3 in.).

5.2.3 Other neutron sources must not be within 9 m (30 ft) of equipment in operation.

6. Apparatus

6.1 *Nuclear Density / Moisture Gauge*—While exact details of construction of the apparatus may vary, the system shall consist of:

6.1.1 *Gamma Source*—A sealed source of high-energy gamma radiation such as cesium or radium.

6.1.2 *Gamma Detector*—Any type of gamma detector such as a Geiger-Mueller tube(s).

6.1.3 *Fast Neutron Source*—A sealed mixture of a radioactive material such as americium, radium and a target material such as beryllium, or a neutron emitter such as californium-252.

6.1.4 *Slow Neutron Detector*—Any type of slow neutron detector such as boron trifluoride or helium-3 proportional counter.

6.2 *Reference Standard*—A block of material used for checking instrument operation, correction of source decay, and to establish conditions for a reproducible reference count rate.

6.3 *Site Preparation Device*—A plate, straightedge, or other suitable leveling tool that may be used for planing the test site to the required smoothness, and in the Direct Transmission Method, guiding the drive pin to prepare a perpendicular hole.

6.4 *Drive Pin*—A pin of slightly larger diameter than the probe in the Direct Transmission Instrument used to prepare a hole in the test site for inserting the probe.

6.4.1 *Drive Pin Guide*—A fixture that keeps the drive pin perpendicular to the test site. Generally part of the site preparation device.

6.5 *Hammer*—Heavy enough to drive the pin to the required depth without undue distortion of the hole.

6.6 *Drive Pin Extractor*—A tool that may be used to remove the drive pin in a vertical direction so that the pin will not distort the hole in the extraction process.

6.7 *Slide Hammer*, with a drive pin attached, may also be used both to prepare a hole in the material to be tested and to extract the pin without distortion to the hole.

7. Hazards

7.1 These gauges utilize radioactive materials that may be hazardous to the health of the users unless proper precautions are taken. Users of these gauges must become familiar with applicable safety procedures and government regulations.

7.2 Effective user instructions, together with routine safety procedures and knowledge of and compliance with Regulatory Requirements, are a mandatory part of the operation and storage of these gauges.

8. Calibration

8.1 Calibration of the gauge will be in accordance with Annex A1 and Annex A2.

8.2 For further reference on gauge calibration, see Guide D 7013, Standard Guide for Nuclear Surface Moisture and Density Gauge Calibration Facility Setup.

9. Standardization

9.1 Nuclear moisture density gauges are subject to long-term aging of the radioactive sources, which may change the relationship between count rates and the material density and water content. To correct for this aging effect, gauges are calibrated as a ratio of the measurement count rate to a count rate made on a reference standard or to an air-gap count (for the backscatter/air-gap ratio method).

9.2 Standardization of the gauge shall be performed at the start of each day's use, and a record of these data should be retained for the amount of time required to ensure compliance with either subsection 9.2.2 or 9.2.3, whichever is applicable. Perform the standardization with the gauge located at least 9 m (30 ft) away from other nuclear moisture density gauges and clear of large masses of water or other items which can affect the reference count rates.

9.2.1 Turn on the gauge and allow for stabilization according to the manufacturer's recommendations. If the gauge is to be used either continuously or intermittently during the day, it is best to leave it in the "power on" condition to prevent having to repeat the stabilization (refer to manufacturer's recommendations). This will provide more stable, consistent results.

9.2.2 Using the reference standard, take at least four repetitive readings at the normal measurement period and obtain the mean. If available on the gauge, one measurement at four or more times the normal measurement period is acceptable. This constitutes one standardization check.

Use the procedure recommended by the gauge manufacturer to establish the compliance of the standard measurement to the accepted range. Without specific recommendations from the gauge manufacturer, use the procedure in 9.2.3.

9.2.3 If the value of the current standardization count is outside the limits set by Eq 1, repeat the standardization check.

If the second standardization check satisfies Eq 1, the gauge is considered in satisfactory operating condition. If the second standardization check does not satisfy Eq 1, the gauge calibration should be checked and verified according to [Annex A1 and Annex A2](#), Sections [A1.2 and A2.2](#). If the verification shows that the gauge meets the requirements of both [Annex A1 and Annex A2](#), Sections [A1.2 and A2.2](#), then, a new reference standard count, N_o , should be established.

If the verification check shows that the gauge fails to meet the requirements of both [Annex A1 and Annex A2](#), Section [A1.2 and A2.2](#), then repair and recalibrate the gauge.

$$N_s = N_o + 1.96 \sqrt{(N_o / F)} \quad (1)$$

where:

N_s = value of current standardization count,

N_o = average of the past four values of N_s taken for prior usage.

F = factory pre-scale factor. The pre-scale value (F) is a divisor which reduces the actual value for the purpose of display. The manufacturer will supply this value if other than 1.0. Some instruments may have provisions to compute and display this value

9.2.3.1 If a gauge has not had a standard count taken for three months or more, the user should repeat the standardization procedure in this section or follow the recommendations of the manufacturer. If for any reason the measured density becomes suspect during the day's use, perform another standardization check.

10. Procedure

10.1 Always select a test location where the gauge will be placed at least 150 mm (6 in.) away from any vertical mass; and anytime the measurements are going to be conducted within 600 mm (24 inches) of a vertical projection, such as in a trench, follow the gauge manufacturer's correction procedures.

10.2 *Prepare the test site in the following manner:*

10.2.1 Remove all loose and disturbed material and additional material as necessary to expose the true surface of the material to be tested.

10.2.2 Prepare a horizontal area sufficient in size to accommodate the gauge by grading or scraping the area to a smooth condition so as to obtain maximum contact between the gauge and material being tested.

10.2.3 The depth of the maximum void beneath the gauge shall not exceed 3 mm ($\frac{1}{8}$ in.). Use native fines or fine sand to fill the voids and smooth the surface with a rigid straight edge or other suitable tool. The depth of the filler should not exceed approximately 3 mm ($\frac{1}{8}$ in.).

10.2.4 The placement of the gauge on the surface of the material to be tested is critical to accurate density measurements. The optimum condition is total contact between the bottom surface of the gauge and the surface of the material being tested. The total area filled should not exceed approximately 10 percent of the bottom area of the gauge.

10.3 Turn on and allow the gauge to stabilize (warm up) according to the manufacturer's recommendations (see Section [9.2.1](#)).

10.4 *Procedure A - The Direct Transmission Procedure:*

10.4.1 Select a test location where the gauge in test position will be at least 150 mm (6 in.) away from any vertical projection

10.4.2 Make a hole perpendicular to the prepared surface using the rod guide and drive pin. The hole should be a minimum of 50 mm (2 inches) deeper than the desired measurement depth and of an alignment that insertion of the probe will not cause the gauge to tilt from the plane of the prepared area.

10.4.3 Mark the test area to allow the placement of the gauge over the test site and to align the source rod to the hole. Follow the manufacturer's recommendations if applicable.

10.4.4 Remove the hole-forming device carefully to prevent the distortion of the hole, damage to the surface, or loose material to fall into the hole.

NOTE 2—Care must be taken in the preparation of the access hole in uniform cohesionless granular soils. Measurements can be affected by damage to the density of surrounding materials when forming the hole.

10.4.5 Place the gauge on the material to be tested, ensuring maximum surface contact as described previously in [10.2.4](#).

10.4.6 Lower the probe into the hole to the desired test depth. Pull the gauge gently toward the back, or detector end, so that the back side of the probe is in intimate contact with the side of the hole in the gamma measurement path.

NOTE 3—As a safety measure, it is recommended that a probe containing radioactive sources not be extended out of its shielded position prior to placing it into the test site. When possible, align the gauge so as to allow placing the probe directly into the test hole from the shielded position.

10.4.7 Keep all other radioactive sources at least 9 m (30 feet) away from the gauge to avoid any effect on the measurement.

10.4.8 If the gauge is so equipped, set the depth selector to the same depth as the probe.

10.4.9 Secure and record one or more one-minute density and water content readings. Read the in-place wet density directly or determine one by use of the calibration curve or table previously established.

10.4.10 Read the water content directly or determine the water content by use of the calibration curve or table previously established.

10.5 *Procedure B - The Backscatter or Backscatter/Air-Gap Ratio Procedure:*

10.5.1 Seat the gauge firmly (see [Note 2](#)).

10.5.2 Keep all other radioactive sources at least 9m (30 ft) away from the gauge to avoid affecting the measurement.

10.5.3 Set the gauge into the Backscatter (BS) position.

10.5.4 Secure and record one or more set(s) of one-minute density and water content readings. When using the backscatter/air-gap ratio mode, follow the manufacturer's instructions regarding gauge setup. Take the same number of readings for the normal measurement period in the air-gap position as in the standard backscatter position. Calculate the air-gap ratio by dividing the counts per minute obtained in the air-gap position by the counts per minute obtained in the standard position. Many gauges have built-in provisions for automatically calculating the air-gap ratio and wet density.

10.5.5 Read the in-place wet density or determine one by use of the calibration curve or table previously established.

10.5.6 Read the water content or determine one by use of the calibration curve or previously established table (see Section 10.6).

10.6 *Water Content Correction and Oversize Particle Correction*

10.6.1 For proper use of the gauge and accurate values of both water content and dry density, both of these corrections need to be made when applicable.

Prior to using the gauge-derived water content on any new material, the value should be verified by comparison to another ASTM method such as Test Methods **D 2216**, **D 4643**, **D 4944**, or **D 4959**. As part of a user developed procedure, occasional samples should be taken from beneath the gauge and comparison testing done to confirm gauge-derived water content values. All gauge manufacturers have a procedure for correcting the gauge-derived water content values.

10.6.2 When oversize particles are present, the gauge can be rotated about the axis of the probe to obtain additional readings as a check. When there is any uncertainty as to the presence of these particles it is advisable to sample the material beneath the gauge to verify the presence and the relative proportion of the oversize particles. A rock correction can then be made for both water content and wet density by the method in Practice **D 4718**.

10.6.3 When sampling for water content correction or oversize particle correction, the sample should be taken from a zone directly under the gauge. The size of the zone is approximately 200 mm (8 in.) in diameter and a depth equal to the depth setting of the probe when using the direct transmission mode; or approximately 75 mm (3 in.) in depth when using the backscatter mode.

11. Calculation of Results

11.1 *Determine the Wet Density*

11.1.1 On most gauges read the value directly in kg/m³ (lbm/ft³). If the density reading is in “counts”, determine the in-place wet density by use of this reading and the previously established calibration curve or table for density.

11.1.2 Record the density to the nearest 1 kg/m³ (0.1 lbm/ft³).

11.2 *Water Content*

11.2.1 Use the gauge reading for w(%) of dry weight of soil, if the gauge converts to that value.

11.2.2 If the gauge determines water mass per unit volume in kg/m³ (lbm / ft³), calculate w using the formula:

$$w = \frac{M_m \times 100}{\rho_d} \quad (2)$$

or,

$$w = \frac{M_m \times 100}{\rho - M_m} \quad (3)$$

where:

- w = water content in percent of dry density
- ρ_d = dry density in kg/m³ or (lbm/ft³),
- ρ = wet density in kg/m³ or (lbm/ft³), and
- M_m = water mass per unit volume in kg/m³ or (lbm/ft³)

11.2.3 If the water content reading was in “counts”, determine the water mass per unit volume by use of this reading and previously established calibration curve or table. Then convert to gravimetric water content as per 11.2.2.

11.2.4 Record water content to the nearest 0.1 %.

11.3 *Determine the Dry Density of the soil by one of the following methods:*

11.3.1 If the water content is obtained by nuclear methods, use the gauge readings directly for dry density in kg/m³ (lbm/ft³). The value can also be calculated from:

$$\rho_d = \rho - M_m \quad (4)$$

11.3.2 If the water content is to be determined from a sample of soil taken as prescribed in (10.6.3), follow the procedures and perform the calculations of the chosen Test Method (**D 2216**, **D 4643**, **D 4944**, or **D 4959**).

11.3.3 With a water content value from 11.3.2 calculate the dry density from:

$$\rho_d = \frac{100 \times \rho}{100 + w} \quad (5)$$

11.3.4 Report the dry density to the nearest 1 kg/m³ (0.1 lbm/ft³).

11.4 *Determine the Percent Compaction:*

11.4.1 It may be desired to express the in-place dry density as a percentage of a laboratory density such as Test Methods **D 698**, **D 1557**, **D 4253**, or **D 4254**. This relationship can be calculated by dividing the in-place dry density by the laboratory maximum dry density and multiplying by 100. Procedures for calculating relative density are provided in Test Method **D 4254** which requires that Test Method **D 4253** also be performed. Corrections for oversize material, if required, should be performed in accordance with Practice **D 4718**.

12. Report: Test Data Sheet(s)/Form(s)/Final Report(s)

12.1 *The Field Data Records shall include, as a minimum, the following:*

- 12.1.1 Test Number or Test Identification.
- 12.1.2 Location of test (e.g.-Station number or GPS or Coordinates or other identifiable information).
- 12.1.3 Visual description of material tested.
- 12.1.4 Lift number or elevation or depth.
- 12.1.5 Name of the operator(s).
- 12.1.6 Make, model and serial number of the test gauge
- 12.1.7 Test mode, Method A (direct transmission and test depth), or Method B (backscatter, backscatter/air-gap),
- 12.1.8 Standardization and adjustment data for the date of the tests.
- 12.1.9 Any corrections made in the reported values and reasons for these corrections (i.e. over-sized particles, water content)
- 12.1.10 Maximum laboratory density value in kg/m³ or lbm/ft³.
- 12.1.11 Dry density in kg/m³ or lbm/ft³.
- 12.1.12 Wet density in kg/m³ or lbm/ft³.
- 12.1.13 Water content in percent
- 12.1.14 Percent Compaction.
- 12.2 *Final Report (minimum required information):*
 - 12.2.1 Test Number.
 - 12.2.2 Gauge Serial number.

- 12.2.3 Location of test (eg.-Station number or GPS or Coordinates or other identifiable information).
- 12.2.4 Lift number or elevation or depth.
- 12.2.5 Moisture (Water) content as a percent.
- 12.2.6 Maximum laboratory density value in kg/m³ or lbm/ft³.
- 12.2.7 Dry Density result in kg/m³ or lbm/ft³.
- 12.2.8 Percent Compaction.
- 12.2.9 Name of Operator(s).

13. Precision and Bias

13.1 Precision:

13.1.1 *Precision – Wet Density*—Criteria for judging the acceptability of wet density test results obtained by this test method are given in **Table 1**. The figure in column three represents the standard deviations that have been found to be appropriate for the materials tested in column one. The figures given in column four are the limits that should not be exceeded by the difference between the results of two properly conducted tests. The figures given are based upon an interlaboratory study in which five test sites containing soils, with wet densities as shown in column two were tested by eight different nuclear gauges and operators. The wet density of each test site was measured three times by each device.

13.1.2 *Precision – Water Content*—Criteria for judging the acceptability of the water content results obtained by this test method are given in **Table 2**. The value in column two is in the units actually reported by the nuclear gauge. The figures in column three represent the standard deviations that have been found to be appropriate for the materials tested in column one. The figures given in column four are the limits that should not be exceeded by the difference between the results of two properly conducted tests. The figures given are based upon an inter-laboratory study in which five test sites containing soils, with water content as shown in column two were tested by eight different nuclear gauges and operators. The water content of each test site was measured three times by each device.

13.2 Bias:

13.2.1 There are no accepted reference values for these test methods, therefore, bias cannot be determined

14. Keywords

14.1 Compaction test; acceptance testing; construction control; quality control; field density; in-place density; wet density; water content; dry density; nuclear methods, nuclear gauge

TABLE 1 Results of Statistical Analysis (Wet Density)^A

| Precision and Soil Type ^B | Average kg/m ³ or (lbm/ft ³) | Standard Deviation kg/m ³ or (lbm/ft ³) | Acceptable Range ^C of Two Results kg/m ³ or (lbm/ft ³) |
|--------------------------------------|---|--|--|
| Single Operator Precision: | | | |
| Direct Transmission: | | | |
| CL | 1837 (114.7) | 5.4 (0.3) | 15.1 (0.9) |
| SP | 1937 (120.9) | 4.3 (0.3) | 11.8 (0.7) |
| ML | 2084 (130.1) | 7.4 (0.5) | 20.5 (1.3) |
| Backscatter: | | | |
| ML | 1996 (124.6) | 19.4 (1.2) | 54.3 (3.4) |
| Multi-laboratory Precision: | | | |
| Direct Transmission: | | | |
| CL | 1837 (114.7) | 10.6 (0.7) | 29.8 (1.9) |
| SP | 1937 (120.9) | 10.9 (0.7) | 30.6 (1.9) |
| ML | 2084 (130.1) | 12.3 (0.8) | 34.4 (2.1) |
| Backscatter: | | | |
| ML | 1996 (124.6) | 38.1 (2.4) | 106.8 (6.7) |

^AThe data used to establish this precision statement is contained in a Research Report available from ASTM Headquarters. Request RR: D18-1004.

^BFor definitions of soil types see Practices **D 2487** and **2488**.

^CTwo separate readings at a singular site with constant gauge orientation and settings.

TABLE 2 Results of Statistical Analysis of % Water Content^A

| Precision and Soil Type ^B | Average % | Standard Deviation % | Acceptable Range of Two Results ^C |
|--------------------------------------|-----------|----------------------|--|
| Single Operator Precision: | | | |
| CL | 11.8 | 0.38 | 0.9 |
| SP | 18.3 | 0.45 | 1.2 |
| ML | 17.7 | 0.32 | 0.9 |
| Multi-laboratory Precision: | | | |
| CL | 11.8 | 0.50 | 1.4 |
| SP | 18.3 | 0.73 | 2.0 |
| ML | 17.7 | 0.52 | 1.5 |

^AThe data used to establish this precision statement is contained in a Research Report available from ASTM Headquarters. Request RR: D18-1004.

^BFor definitions of soil types see Practices D 2487 and 2488.

^CTwo separate readings at a singular site with constant gauge orientation and settings.

ANNEXES

(Mandatory Information)

A1. WET DENSITY CALIBRATION & VERIFICATION

A1.1 *Calibration:* Gauges shall be calibrated initially and after any repairs that can affect the gauge geometry or the existing calibration. To be within specified tolerances by procedures described in A1.2, calibration curves, tables, or equivalent coefficients shall be verified, at periods not to exceed 12 months. At any time these tolerances cannot be met, the gauge shall be calibrated to establish new calibration curves, tables, or equivalent coefficients. If the owner does not establish a verification procedure, the gauge shall be calibrated at a period not to exceed 12 months.

A1.1.1 Gauge Calibration Response shall be within ± 16 kg/m³ (± 1.0 lbm/ft³) on the block(s) on which the gauge was calibrated. This calibration may be done by the manufacturer, the user, or an independent vendor. Nuclear gauge response is influenced by the chemical composition of measured materials. This response must be taken into account in establishing the block density. The method used for calibration shall be capable of generating a general curve covering the entire density range of the materials to be tested in the field. The density of the block(s) shall be determined in such a manner that the estimated standard deviation of the measurement results shall not exceed 0.2 % of the measured block density.

A1.1.2 Reestablish or verify the density of the block(s) used to calibrate or verify calibrations at a period not to exceed 5 years. The density values of the established block(s) of materials that have the potential for changes over time in density or moisture content, such as soil, concrete, or solid rock, shall be reestablished or verified at periods not exceeding 12 months.

NOTE A1.1—Changes in background conditions or locations of blocks used for gauge calibrations or verification of calibrations can impact measurements on those blocks. Care must be taken to ensure uniform conditions when performing gauge calibrations or verifying gauge calibrations.

A1.1.3 Sufficient data shall be taken on each density block to ensure a gauge count precision of at least one-half the gauge

count precision required for field use assuming field use measurement of one minute duration and four-minute duration used for calibration, or an equivalent relationship. The data may be presented in the form of a graph, table, equation coefficients, or stored in the gauge, to allow converting the count rate data to density.

A1.1.4 The method and test procedures used in establishing the calibration count rate data shall be the same as those used for obtaining the field count rate data.

A1.1.5 The material type, actual density, or established density of each calibration block used to establish or verify the gauge calibration shall be stated as part of the calibration data for each measurement depth. If the actual or established block density varies with measurement depth, then the density data for each measurement depth shall be stated as part of the calibration.

A1.1.6 The calibration blocks should be sufficient in size so that the count rate will not change if the block is enlarged in any dimension.

NOTE A1.2—Minimum surface dimensions of approximately 610 mm by 430 mm (24 × 17 inches), have proven satisfactory. For the backscatter method a minimum depth of 230 mm (9 inches) is adequate; while for the direct transmission method the depth should be at least 50 mm (2 inches) deeper than the deepest rod penetration depth. A larger surface area should be considered for the backscatter/air-gap method. For blocks with widths or lengths smaller than the sizes specified, follow the block manufacturer's recommendations for proper installation and use.

The most successful blocks that have been established for calibration have been made of magnesium, aluminum, aluminum/magnesium, granite, and limestone. These blocks have been used in combination with each other, with historical curve information, and with other prepared block(s) to produce accurate and reliable calibration.

A1.2 *Verification:* The method used for verification should be capable of verifying the general calibration curve representing the density range of the materials to be tested in the field. The verification process and the resulting tolerances obtained over the depths at which the gauge will be used, shall be

formally recorded and documented. If this verification process indicates a variance beyond the specified tolerances, the gauge shall be calibrated

A1.2.1 Gauge verification response shall be within $\pm 32 \text{ kg/m}^3 (\pm 2.9 \text{ lbm/ft}^3)$ on block(s) of established density at each calibration depth.

A1.2.2 Using the procedure described in either A3.1.1 or A3.1.2, ensure a gauge count precision of at least one-half the gauge count precision required for field use, assuming field use measurement of one-minute duration and four-minute duration are used for calibration, or an equivalent relationship.

A1.2.3 The gauge calibration may be verified on calibration block(s) which were used for calibration of the gauge, or prepared blocks.

A1.2.4 Prepared block(s) of soil, solid rock, concrete, and engineered block(s) that have characteristics of reproducible

uniformity may be used, but care must be taken to establish density values and to minimize changes in density and water content over time.

A1.2.5 Density values of prepared block(s) shall be determined in such a manner that the estimated standard deviation of the measurement results shall not exceed 0.5 % of the measured block density value.

A1.2.6 Reestablish or verify density values for prepared block(s) of soil, solid rock, or concrete that have the potential of changes over time in density or moisture content at periods not exceeding 12 months.

A1.2.7 The method used to establish or verify the block(s) density values shall be stated as part of the verification data.

A1.2.8 All gauges shall be verified or calibrated at a minimum frequency of 12 months.

A2. WATER CONTENT CALIBRATION and VERIFICATION

A2.1 *Calibration:* Gauges shall be calibrated initially and after any repairs that can affect the gauge geometry or the existing calibration. Calibration curves, tables, or equivalent coefficients shall be verified at periods, not exceeding 12 months, to be within specified tolerances by procedures described in A2.2. At any time these tolerances cannot be met, the gauge shall be calibrated to establish new calibration curves, tables, or equivalent coefficients. If the owner does not establish a verification procedure, the gauge shall be calibrated at a period not to exceed 12 months.

A2.1.1 Gauge Calibration Response shall be within $16 \text{ kg/m}^3 (1 \text{ lbm/ft}^3)$ on the block(s) on which the gauge was calibrated. This calibration may be done by the gauge manufacturer, the user, or an independent vendor. The block(s) used for calibration should be capable of generating a general curve covering the entire water content range of the materials to be tested in the field. The calibration curve can be established using counts and water contents of standard blocks, previous factory curve information, or historical data. Due to the effect of chemical composition, the calibration supplied by the manufacturer with the gauge will not be applicable to all materials. It shall be accurate for silica and water; therefore, the calibration must be verified and adjusted, if necessary, in accordance with section A2.2

A2.1.2 Reestablish or verify the assigned water content of blocks used to calibrate or verify calibrations at periods which shall be recommended by the block manufacturer. The water content values of blocks prepared of materials that have the potential of changes over time in density or moisture content, such as soil, concrete, or solid rock, shall be reestablished or verified at periods not exceeding 12 months.

A2.1.3 All calibration blocks should be sufficient in size so that the count rate will not change if the block is enlarged in any dimension.

NOTE A2.1—Dimensions of approximately 610 mm long by 460 mm wide by 200 mm deep (approximately 24 by 18 by 8 inches) have proven

satisfactory. For blocks with width or length smaller than the sizes specified, follow block manufacturer's recommendations for proper installation and use.

A2.1.4 Prepare a homogeneous block of hydrogenous materials having an equivalent water content, determined by comparison (using a nuclear instrument), with a saturated silica sand standard prepared in accordance with A2.1.3. Metallic blocks used for wet density calibration such as magnesium or aluminum are a convenient zero water content block. A block of alternating sheets of aluminum or magnesium and polyethylene is convenient for a high water content block.

A2.1.5 Prepare containers of compacted material with a water content determined by oven dry (Test Method D 2216) and a wet density calculated from the mass of the material and the inside dimensions of the container. The water mass per unit volume may be calculated as follows:

$$M_m = \frac{\rho \times w}{100 + w} \quad (\text{A2.1})$$

Where:

M_m = water mass per unit volume, kg/m^3 or lbm/ft^3 ,

w = water content, percent of dry mass, and

ρ = wet (total) density, kg/m^3 or lbm/ft^3 .

A2.1.6 Where neither of the previous calibration standards are available, the gauge may be calibrated by using a minimum of three selected test sites in an area of a compaction project where material has been placed at several different water contents. The test sites shall represent the range of water contents over which the calibration is to be used. At least three replicate nuclear measurements shall be made at each test site. The density at each site shall be verified by measurements with calibrated equipment in accordance with the procedures described in this standard, Test Methods D 1556, D 2167, or D 2937. The water content of the material at each of the test sites shall be determined using Test Method D 2216. Use the mean value of the replicate readings as the calibration point value for each test site.

A2.2 *Verification:* The method used for verification should

be capable of verifying the general calibration curve representing the water content of the materials to be tested in the field. The verification process and resultant tolerances obtained shall be formally recorded and documented. If the verification process indicates a variance beyond the specified tolerances, new calibration curves, tables, or equivalent coefficients shall be established.

A2.2.1 Verify an existing calibration by taking sufficient number of counts on one or more blocks of established water content to ensure the accuracy of the existing calibration within $\pm 16 \text{ kg/m}^3$ or $(\pm 1 \text{ lbm/ft}^3)$. The water content block(s) should be prepared in accordance with section [A2.1.4](#) and [A2.1.5](#)

A2.2.2 Sufficient data shall be taken to ensure a gauge count precision of at least one half the gauge count precision required

for field use assuming field use measurement of one minute duration and four minute duration used for calibration, or an equivalent relationship.

A2.2.3 Calibration block(s) used to establish calibration parameters and prepared blocks can be used to verify calibration.

A2.2.4 Prepared block(s) that have characteristics of reproducible uniformity can be used, but care must be taken to minimize changes in density and water content over time.

A2.2.5 The established water content of the block(s) used for verification of the gauge shall be stated as part of the verification data.

A2.2.6 All gauges shall be verified or calibrated at a minimum frequency of 12 months.

A3. GAUGE PRECISION

A3.1 Gauge precision is defined as the change in density or water mass per unit volume that occurs corresponding to a one standard deviation change in the count due to the random decay of the radioactive source. The density of the material and time period of the count must be stated.

Calculate using the methods in either [A3.1.1](#) or [A3.1.2](#). For wet density, use a material having a density of $2000 \pm 80 \text{ kg/m}^3$ ($125.0 \pm 5.0 \text{ lbm/ft}^3$). Typical values of P are $< 10 \text{ kg/m}^3$ (0.6 lbm/ft^3) in backscatter or backscatter/air-gap; and $< 5 \text{ kg/m}^3$ (0.3 lbm/ft^3) for direct transmission measured at a 15 cm (6 in) depth. Use a water mass per unit volume value of $160 \pm 10 \text{ kg/m}^3$ ($10.0 \pm 0.6 \text{ lbm/ft}^3$) for determining slope and count rates. The value of P is typically less than 4.8 kg/m^3 (0.3 lbm/ft^3).

A3.1.1 Gauge Precision - Slope Method

Determine the gauge precision of the system, P , from the slope of the calibration curve, S , and the standard deviation, σ ,

of the signals (detected gamma rays or detected neutrons) in counts per minute (cpm), as follows:

$$P = \sigma/S \quad (\text{A3.1})$$

where:

P = precision

σ = standard deviation, cpm

S = slope, cpm/kg/m^3 or cpm/lbm/ft^3

NOTE A3.1—Displayed gauge counts may be scaled. Contact the manufacturer to obtain the appropriate pre-scale factor.

A3.1.2 Gauge Precision – Repetitive Method

Determine the standard deviation of a minimum of 20 repetitive readings of one minute each, without moving the gauge between readings. Calculate the standard deviation of the resulting readings. This is the gauge precision.

A4. FIELD MOISTURE CONTENT ADJUSTMENTS

A4.1 The calibration should be checked prior to performing tests on materials that are distinctly different from material types previously used in obtaining or adjusting the calibration. Sample materials may be selected by either [A2.1.5](#) or [A2.1.6](#). The amount of water shall be within $\pm 2\%$ of the water content established as optimum for compaction for these materials. Determine the water content w . A microwave oven or direct heater may be utilized for drying materials that are not sensitive to combustion of organic material, in addition to the method listed in [A2.1.6](#). A minimum of three comparisons is recommended and the mean of the observed differences used as the correction factor.

A4.2 Container(s) of compacted material taken from the test site shall be prepared in accordance with [A2.1.5](#).

A4.3 Test site(s) or the compacted material shall be selected in accordance with the procedures in [A2.1.6](#).

A4.4 The method and test procedures used in obtaining the count rate to establish the error must be the same as those used for measuring the water content of the material to be tested.

A4.5 The mean value of the difference between the moisture content of the test samples as determined in [A2.1.5](#) or [A2.1.6](#) and the values measured with the gauge shall be used as a correction to measurements made in the field. Many gauges utilizing a microprocessor have provision to input a correction factor that is established by the relative values of water content as a percentage of dry density, thus eliminating the need to determine the difference in mass units of water.

SUMMARY OF CHANGES

In accordance with Committee D18 policy, this section identifies the location of changes to this standard since the last published edition (06^{e1}) that may impact the use of this standard.

- (1) Section 12 was added because users of this test method have correctly indicated that there are two reports that should be addressed: the “field data record”, or the report containing the data that are acquired in the field, and the “final report”, or the data that are ultimately supplied to the customer for their use. The field data record and the final report contain much of the same information, but they are distinct in some of the information that they contain and disseminate.

ASTM International takes no position respecting the validity of any patent rights asserted in connection with any item mentioned in this standard. Users of this standard are expressly advised that determination of the validity of any such patent rights, and the risk of infringement of such rights, are entirely their own responsibility.

This standard is subject to revision at any time by the responsible technical committee and must be reviewed every five years and if not revised, either reapproved or withdrawn. Your comments are invited either for revision of this standard or for additional standards and should be addressed to ASTM International Headquarters. Your comments will receive careful consideration at a meeting of the responsible technical committee, which you may attend. If you feel that your comments have not received a fair hearing you should make your views known to the ASTM Committee on Standards, at the address shown below.

This standard is copyrighted by ASTM International, 100 Barr Harbor Drive, PO Box C700, West Conshohocken, PA 19428-2959, United States. Individual reprints (single or multiple copies) of this standard may be obtained by contacting ASTM at the above address or at 610-832-9585 (phone), 610-832-9555 (fax), or service@astm.org (e-mail); or through the ASTM website (www.astm.org).



Designation: D3385 – 18

Standard Test Method for Infiltration Rate of Soils in Field Using Double-Ring Infiltrometer¹

This standard is issued under the fixed designation D3385; the number immediately following the designation indicates the year of original adoption or, in the case of revision, the year of last revision. A number in parentheses indicates the year of last reappraisal. A superscript epsilon (ϵ) indicates an editorial change since the last revision or reappraisal.

This standard has been approved for use by agencies of the U.S. Department of Defense.

1. Scope*

1.1 This test method describes a procedure for field measurement of the rate of infiltration of liquid (typically water) into soils using double-ring infiltrometer.

1.2 The infiltrometer is installed by driving into the soil. The infiltrometer also may be installed in a trench excavated in dry or stiff soils.

1.3 Soils should be regarded as natural occurring soils or processed materials or mixtures of natural soils and processed materials, or other porous materials, and which are basically insoluble and are in accordance with requirements of 1.6.

1.4 This test method is particularly applicable to relatively uniform fine-grained soils, with an absence of very plastic (fat) clays and gravel-size particles and with moderate to low resistance to ring penetration.

1.5 This test method may be conducted at the ground surface or at given depths in pits, and on bare soil or with vegetation in place, depending on the conditions for which infiltration rates are desired. However, this test method cannot be conducted where the test surface is below the groundwater table or perched water table.

1.6 This test method is difficult to use or the resultant data may be unreliable, or both, in very pervious or impervious soils (soils with a hydraulic conductivity greater than about 10^{-2} cm/s or less than about 1×10^{-5} cm/s) or in dry or stiff soils if these fracture when the rings are installed. For soils with hydraulic conductivity less than 1×10^{-5} cm/s refer to Test Method D5093.

1.7 This test method cannot be used directly to determine the hydraulic conductivity (coefficient of permeability) of the soil (see 5.2).

1.8 *Units*—The values stated in SI units are to be regarded as the standard. The inch-pound units given in parentheses are mathematical conversions, which are provided for information purposes only and are not considered standard.

1.9 *This standard does not purport to address all of the safety concerns, if any, associated with its use. It is the responsibility of the user of this standard to establish appropriate safety, health, and environmental practices and determine the applicability of regulatory limitations prior to use.*

1.10 *This international standard was developed in accordance with internationally recognized principles on standardization established in the Decision on Principles for the Development of International Standards, Guides and Recommendations issued by the World Trade Organization Technical Barriers to Trade (TBT) Committee.*

2. Referenced Documents

2.1 ASTM Standards:²

- D653 Terminology Relating to Soil, Rock, and Contained Fluids
- D1452 Practice for Soil Exploration and Sampling by Auger Borings
- D2216 Test Methods for Laboratory Determination of Water (Moisture) Content of Soil and Rock by Mass
- D2488 Practice for Description and Identification of Soils (Visual-Manual Procedures)
- D3740 Practice for Minimum Requirements for Agencies Engaged in Testing and/or Inspection of Soil and Rock as Used in Engineering Design and Construction
- D5093 Test Method for Field Measurement of Infiltration Rate Using Double-Ring Infiltrometer with Sealed-Inner Ring

3. Terminology

3.1 *Definitions*—For common definitions of technical terms in this standard, refer to Terminology D653.

¹ This test method is under the jurisdiction of ASTM Committee D18 on Soil and Rock and is the direct responsibility of Subcommittee D18.04 on Hydrologic Properties and Hydraulic Barriers.

Current edition approved March 1, 2018. Published April 2018. Originally approved in 1975. Last previous edition approved in 2009 as D3385 – 09. DOI: 10.1520/D3385-18.

² For referenced ASTM standards, visit the ASTM website, www.astm.org, or contact ASTM Customer Service at service@astm.org. For *Annual Book of ASTM Standards* volume information, refer to the standard's Document Summary page on the ASTM website.

*A Summary of Changes section appears at the end of this standard

3.2 Definitions of Terms Specific to This Standard:

3.2.1 *incremental infiltration velocity*—the quantity of flow per unit area over an increment of time. It has the same units as the infiltration rate.

3.2.2 *infiltration*—the downward entry of liquid into the soil.

3.2.3 *infiltration rate*—the rate, based on measured incremental infiltration velocities, at which liquid can enter the soil under specified conditions. During infiltration, this rate may decrease with time until reaching a quasi-steady value.

3.2.4 *infiltrometer*—a device for measuring the rate of entry of liquid into a porous body, for example, water into soil.

4. Summary of Test Method

4.1 The double-ring infiltrometer method consists of installing two open cylinders, one inside the other, into the ground, partially filling the rings with water or other liquid, and then maintaining the liquid at a constant level. The volume of liquid added to the inner ring, to maintain the liquid level constant is the measure of the volume of liquid that infiltrates the soil. The volume infiltrated during timed intervals is converted to an incremental infiltration velocity by dividing by the area of the inner ring, usually expressed in centimeter per hour (or inch per hour) and plotted versus elapsed time. The maximum steady-state or average incremental infiltration velocity, depending on the purpose/application of the test is equivalent to the infiltration rate.

5. Significance and Use

5.1 This test method is useful for field measurement of the infiltration rate of soils. Infiltration rates have application to such studies as liquid waste disposal, evaluation of potential septic-tank disposal fields, leaching and drainage efficiencies, irrigation requirements, water spreading and recharge, and canal or reservoir leakage, among other applications.

5.2 Although the units of infiltration rate and hydraulic conductivity of soils are similar, there is a distinct difference between these two quantities. They cannot be directly related unless the hydraulic boundary conditions are known, such as hydraulic gradient and the extent of lateral flow of water, or can be reliably estimated.

5.3 The purpose of the outer ring is to promote one-dimensional, vertical flow beneath the inner ring.

5.4 Many factors affect the infiltration rate, for example the soil structure, soil layering, condition of the soil surface, degree of saturation of the soil, chemical and physical nature of the soil and of the applied liquid, head of the applied liquid, temperature of the liquid, and diameter and depth of embedment of rings.³ Thus, tests made at the same site are not likely to give identical results and the rate measured by the test method described in this standard is primarily for comparative use.

³ Discussion of factors affecting infiltration rate is contained in the following reference: Johnson, A. I., *A Field Method for Measurement of Infiltration*, U.S. Geological Survey Water-Supply Paper 1544-F, 1963, pp. 4–9.

5.5 Some aspects of the test, such as the length of time the tests should be conducted and the head of liquid to be applied, must depend upon the experience of the user, the purpose for testing, and the kind of information that is sought.

NOTE 1—The quality of the result produced by this standard is dependent on the competence of the personnel performing it, and the suitability of the equipment and facilities used. Agencies that meet the criteria of Practice D3740 are generally considered capable of competent and objective testing/sampling/inspection/etc. Users of this standard are cautioned that compliance with Practice D3740 does not in itself assure reliable results. Reliable results depend on many factors; Practice D3740 provides a means of evaluating some of those factors.

6. Apparatus

6.1 *Infiltrometer Rings*—Cylinders approximately 500 mm (20 in.) high and having diameters of about 300 and 600 mm (12 and 24 in.). Larger cylinders may be used but the ratio of the outer to inner cylinder diameters is about two times. Cylinders can be made of 3-mm (1/8-in.), hard-alloy, aluminum sheet or other material sufficiently strong to withstand hard driving, with the bottom edge beveled (see Fig. 1). The beveled edges shall be kept sharp. Stainless steel or strong plastic rings may have to be used when working with corrosive fluids.

6.2 *Driving Caps*—Disks of 13-mm (1/2-in.) thick hard-alloy aluminum with centering pins around the edge, or preferably having a recessed groove about 5 mm (0.2 in.) deep with a width about 1 mm (0.05 in.) wider than the thickness of the ring. The diameters of the disks should be slightly larger than those of the infiltrometer rings.

6.3 *Driving Equipment*—A 5.5-kg (12-lb) maul or sledge and a 600 or 900-mm (2 or 3-ft) length of wood approximately 50 by 100 mm or 100 by 100 mm (2 by 4 in. or 4 by 4 in.), or a jack and reaction of suitable size.

6.4 *Grout*—A commercial bentonite grout product and water mix having 30 % bentonite solids for filling the trenches and sealing the rings in place (see 8.5).

6.5 *Depth Gauge*—A hook gauge, steel tape or rule, or length of steel or plastic rod pointed on one end, for use in measuring and controlling the depth of liquid (head) in the infiltrometer ring, when either a graduated Mariotte bottle or automatic flow control system is not used.

6.6 *Splash Guard*—Several pieces of rubber sheet or burlap 150 mm (6 in.) square. A large piece of cheese cloth folded several times can also be used as a splash guard.

6.7 *Rule or Tape*—A steel tape having a length of at least 2 m (6.5 ft) or a steel rule having a length of at least 300 mm (1 ft).

6.8 *Tamp*—Any device that is basically rigid, has a handle not less than 550 mm (22 in.) in length, and has a tamping foot with an area ranging from 650 to 4000 mm² (1 to 6 in.²) and a maximum dimension of 150 mm (6 in.).

6.9 *Shovels*—One long-handled shovel and one trenching spade; hand shovel or trowel (for excavating a trench).

6.10 Liquid Containers:

6.10.1 One barrel or other container having a minimum volume of 200 L (55 gal) for the main liquid supply, along with

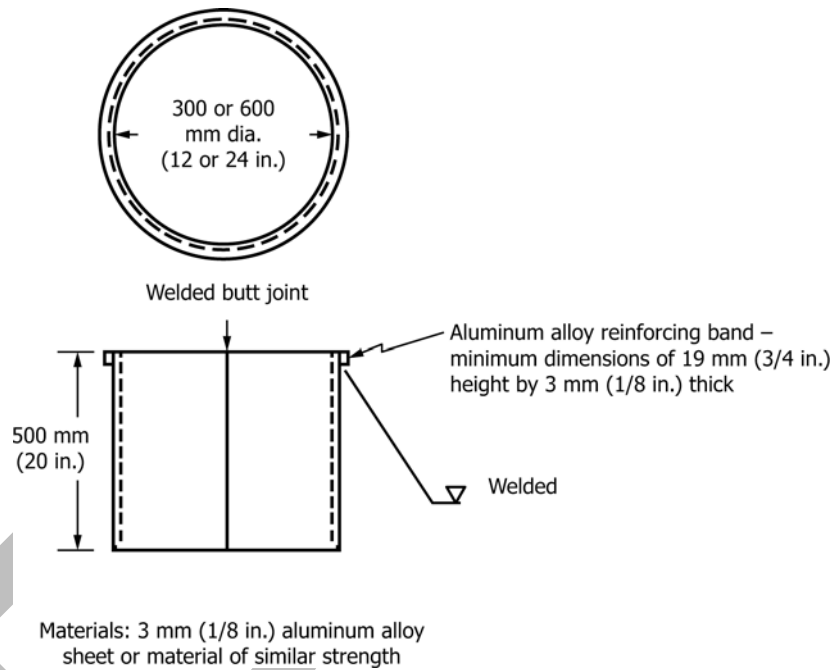

FIG. 1 Infiltrometer Construction

a length of rubber hose to siphon liquid from the barrel to fill the calibrated head tanks (see 6.10.3).

6.10.2 A pail or carboy having a minimum volume capacity of 13 L (12 qt) for initial filling of the infiltrometers.

6.10.3 Two calibrated head tanks for measurement of liquid flow during the test. These may be either graduated cylinders or Mariotte bottles having a minimum volume capacity of 3 L

(3.17 qt) (see Note 2 and Note 3 and Fig. 2). In higher permeability soils, the Mariotte bottle used for the inner and outer rings may have a larger volume to avoid having to refill the bottle during testing.

NOTE 2—Constant-level float valves have been eliminated for simplification of the illustration.

NOTE 3—It is useful to have one head tank with a capacity of three

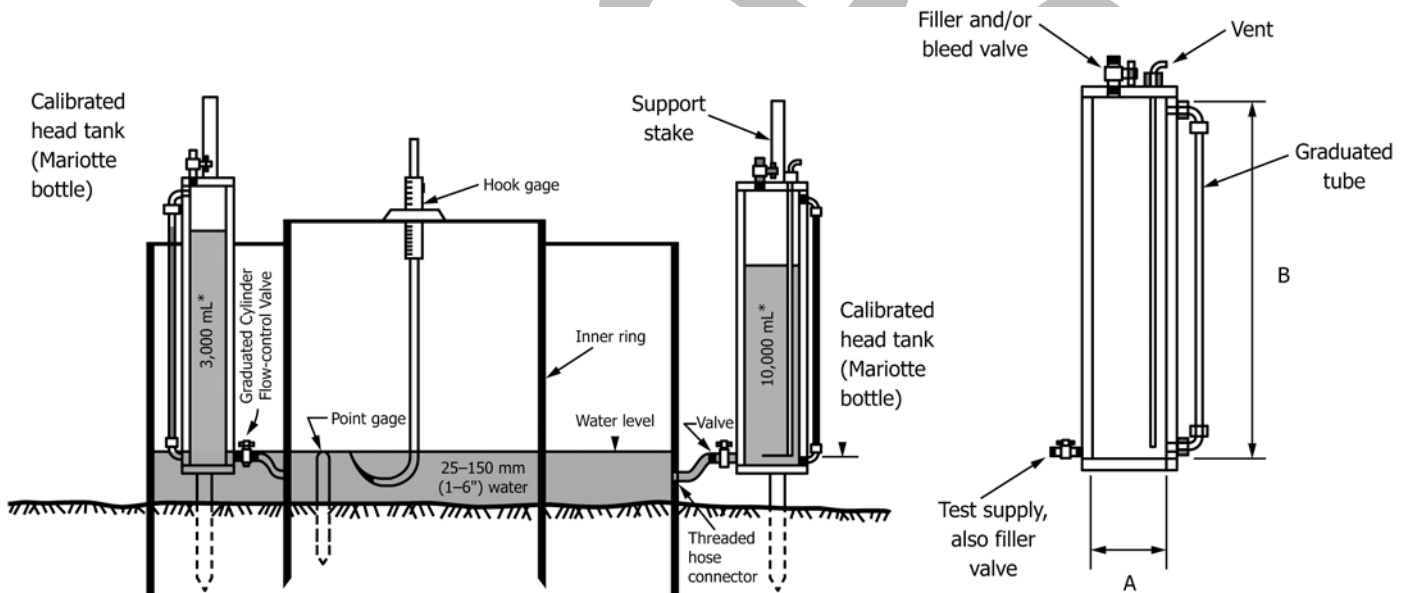

Note: Constant-level float valves have been eliminated for simplification of the illustration

Mariotte bottle typical capacities: 3,000 or 10,000 ml
 A: 100 mm (4 in.) or 150 mm (6 in.)
 B: 450 mm (18 in.) or 600 mm (24 in.)

NOTE 1—Constant-level float valves have been eliminated for simplification of the illustration

FIG. 2 Ring Installation and Mariotte Bottle Details

times that of the other because the area of the annular space between the rings is about three times that of the inner ring.

NOTE 4—In many cases, the volume capacity of these calibrated head tanks must be significantly larger than 3000 mL (3.17 qt), especially if the test has to continue overnight. Capacities of about 50 L (13 gal) would not be uncommon.

6.11 *Liquid Supply*—Water, or preferably, liquid of the same quality and temperature as that involved in the problem being examined. The liquid used must be chemically compatible with the infiltrometer rings and other equipment used to contain the liquid.

NOTE 5—To obtain maximum infiltration rates, the liquid should be free from suspended solids and the temperature of the liquid should be higher than the soil temperature. This will tend to avoid reduction of infiltration

from blockage of voids by particles or gases coming out of solution.

6.12 *Watch or Stopwatch*—Used to measure the time during infiltration.

6.13 *Level*—A carpenter’s level or bull’s-eye (round) level.

6.14 *Thermometer*—With resolution of 0.5°C (1°F) and capable of measuring soil temperature at depth below the ground surface.

6.15 *Rubber Hammer (mallet)*.

6.16 *pH Paper*, in 0.5 increments.

6.17 *Recording Materials*—Record books and graph paper, or special forms with graph section (see Fig. 3 for an example

Project Identification: NRTS_

Test Location: IDAHO - Lost River Alluvium_

Liquid Used: River water pH = 8.0_

Tested by IJA CWJ_

Liquid level maintained using: Mariotte Bottle_

Depth to water table: 5.2 m_

Penetration of rings -- Inner: 7.5 cm ; Outer: 17.5 cm_

Date: 10/14/1982

| Trial No. | | Time (hr:min) | Elapsed Time: Δ/total (min) | Flow Readings | | | | Liquid Temp (°C) | Incremental Infiltration Rate | | Ground Temperature = 14°C at depth of 30 cm Remarks: Weather Conditions, etc. |
|-----------|---|---------------|-----------------------------|---------------|-------------------------|---------------|-------------------------|------------------|-------------------------------|----------------|--|
| | | | | Inner Reading | | Annular Space | | | Inner (cm/h) | Annular (cm/h) | |
| | | | | Reading (cm) | Flow (cm ³) | Reading (cm) | Flow (cm ³) | | | | |
| 1 | S | 10:00 | 15 | 3 | 114 | 2.2 | 389 | 15 | 0.64 | 0.74 | Cloudy, slight wind |
| | E | 10:15 | (15) | 4.45 | | 4.4 | | | | | |
| 2 | S | 10:15 | 15 | 4.45 | 212 | 4.4 | 795 | 15 | 1.2 | 1.5 | |
| | E | 10:30 | (30) | 7.15 | | 8.9 | | | | | |
| 3 | S | 10:30 | 15 | 7.15 | 263 | 8.9 | 848 | 15 | 1.5 | 1.6 | |
| | E | 10:45 | (45) | 10.5 | | 13.7 | | | | | |
| 4 | S | 10:45 | 15 | 10.5 | 306 | 13.7 | 945 | 15 | 1.7 | 1.8 | |
| | E | 11:00 | (60) | 14.4 | | 19.05 | | | | | |
| 5 | S | 11:00 | 30 | 14.4 | 758 | 19.05 | 2324 | 15.5 | 2.1 | 2.2 | |
| | E | 11:30 | (90) | 24.05 | | 32.2 | | | | | |
| 6 | S | 11:30 | 30 | 24.05 | 848 | 32.2 | 2580 | 16 | 2.4 | 2.45 | |
| | E | 12:00 | (120) | 34.85 | | 46.8 | | | | | |
| 7 | S | 12:10 | 60 | 3.5 | 1944 | 2.2 | 5902 | 16.5 | 2.75 | 2.8 | Refilled bottles |
| | E | 13:10 | (180) | 28.25 | | 35.6 | | | | | |
| 8 | S | 13:20 | 60 | 2.4 | 1877 | 3.2 | 5690 | 17.5 | 2.65 | 2.7 | " " |
| | E | 14:20 | (240) | 26.3 | | 35.4 | | | | | |
| 9 | S | 14:30 | 60 | 4.3 | 1696 | 4.7 | 5054 | 17.5 | 2.4 | 2.4 | " " |
| | E | 15:30 | (300) | 25.9 | | 33.3 | | | | | |
| 10 | S | 15:40 | 60 | 2.2 | 1586 | 4.5 | 4842 | 18 | 2.2 | 2.3 | " " |
| | E | 16:40 | (360) | 22.4 | | 31.9 | | | | | |

| Constants | Area (cm ²) | Depth of Liquid (cm) | Liquid No. | Containers Vol/ΔH (cm ³ /cm) |
|---------------|-------------------------|----------------------|------------|---|
| Inner Ring | 707 | 4.0 | 1 | 78.54 |
| Annular Space | 2106 | 4.1 | 2 | 176.7 |

FIG. 3 Data Form for Infiltration Test with Sample Data

of a data form).

6.18 *Hand Auger*—Orchard-type (barrel-type) auger with 75-mm (3-in.) diameter, 225-mm (9-in.) long barrel and a rubber-headed tire hammer for knocking sample out of the auger. This apparatus is optional.

6.19 *Float Valves*—Two constant level float valves (carburetors or bob-float types) with support stands. This apparatus is optional.

6.20 *Covers and Dummy Tests Set-Up*—For long-term tests in which evaporation of fluid from the infiltration rings and unsealed reservoirs can occur (see 8.2.1).

7. Calibration

7.1 Rings:

7.1.1 Determine the area of each ring and the annular space between rings before initial use and before reuse after anything has occurred, including repairs, which may affect the test results significantly.

7.1.2 Determine the area to the nearest 10 mm² (0.15 in.²) or better. Measure the inside diameter (ID) of the outer ring at least six equally-spaced locations around the ID of the ring. Measure both the inside diameter (ID) and the outside diameter (OD) of the inner ring at least at six equally-spaced locations around the ring.

7.1.3 The area of the annular space between rings is equal to the internal area of the 600-mm (24-in.) ring minus the external area of the 300-mm (12-in.) ring.

7.2 *Liquid Containers*—For each graduated cylinder or graduated Mariotte bottle, establish the relationship between the change in elevation of liquid (fluid) level and change in volume of fluid. This relationship shall have an overall accuracy of 1 %.

8. Procedure

8.1 Test Site:

8.1.1 Establish the soil strata to be tested from the soil profile determined by the classification of soil samples from an adjacent auger hole.

NOTE 6—For the test results to be valid, the soil directly below the test zone must have equal or greater flow rates than the test zone.

8.1.2 The test requires an area accessible for delivery of test equipment and sufficiently large for the set up and use of the test system.

8.1.3 The test site should be nearly level, or a level surface should be prepared.

8.1.4 The test may be set up in a pit if infiltration rates are desired at depth rather than at the surface.

8.2 Technical Precautions:

8.2.1 For long-term tests, avoid unattended sites where interference with test equipment is possible, such as sites near children or in pastures with livestock. Also, evaporation of fluid from the rings and unsealed reservoirs can lead to errors in the measured infiltration rate. Therefore, in such tests, completely cover the top of the rings and unsealed reservoirs with a relatively airtight material, but vented to the atmosphere

through a small hole or tube. In addition, make measurements to verify that the rate of evaporation in a similar test configuration (without any infiltration into the soil) is less than 20% of the infiltration rate being measured.

8.2.2 Make provisions to protect the test apparatus and fluid from direct sunlight and temperature variations that are large enough to affect the slow measurements significantly, especially for test durations greater than a few hours or those using a Mariotte bottle. The expansion or contraction of the air in the Mariotte bottle above the water due to temperature changes may cause changes in the rate of flow of the liquid from the bottle which will result in a fluctuating water level in the infiltrometer rings.

8.3 Driving Infiltration Rings with a Sledge:

NOTE 7—Driving rings with a jack is preferred; see 8.4.

8.3.1 Place the driving cap on the outer ring and center it thereon. Place the wood block (see 6.3) on the driving cap.

8.3.2 Drive the outer ring into the soil with blows of a heavy sledge on the wood block to a depth that will (a) minimize the test fluid from leaking to the ground surface surrounding the ring, and (b) exceed the depth to which the inner ring will be driven. Drive the ring to a depth of 150 mm (6 in.). Use blows of medium force to minimize disturbance of the soil surface. Move the wood block around the edge of the driving cap every one or two blows so that the ring will penetrate the soil uniformly. A second person standing on the wood block and driving cap will usually facilitate driving the ring, and reduce vibrations and disturbance.

8.3.3 Center the smaller ring inside the larger ring and drive to a depth within 5 mm of the depth that was used for the outer ring (8.3.2), using the same technique as in 8.3.2. Similar driving depths are used for the outer and inner rings to ensure one-dimensional flow.

8.4 Driving Infiltration Rings with Jacks:

8.4.1 Use a heavy jack under the back end of a truck to drive rings as an alternative to the sledge method (see 8.3).

8.4.2 Center the wood block across the driving cap of the ring. Center a jack on the wood block. Place the top of the jack and the assembled items vertically under the previously positioned end of a truck body and apply force to the ring by means of the jack and truck reaction. Also, tamp near the edges or near the center of the ring with the rubber mallet, as slight tamping and vibrations will reduce hang-ups and tilting of the ring.

8.4.3 Add additional weight to the truck if needed to develop sufficient force to drive the ring.

8.4.4 Check the rings with the level, correcting the attitude of the rings to be vertical, as needed.

8.5 Excavation of Trenches (if used):

8.5.1 Place both rings on the soil to be tested and center the inner ring within the outer ring. Push the rings slightly into the soil to make a mark on the soil surface for use as a guide for excavating the trenches.

8.5.2 Using a spade and trowel, excavate the trench for the inner ring excavate the trench for the outer ring. Excavate both trenches to depths of 150 mm (6 in.). Excavate the trenches carefully to minimize disturbance to the surrounding soils.

8.5.3 Use a hand shovel to remove any loose material in the trenches.

8.5.4 Fill the trenches with a stiff bentonite grout to within approximately 25 mm (1 in.) of the top of the trench.

8.5.5 Lift the inner ring and center the ring over the inner trench. Lower the ring into the trench and slowly push it down. Keep the ring level while pushing it down. Use a trowel to press the grout against the wall of the ring to ensure a good seal.

8.5.6 Lift the outer ring and center the ring over the outer trench. Lower the ring into the trench and slowly push it down. Keep the ring level while pushing it down. Use a trowel to press the grout against the wall of the ring to ensure a good seal.

8.5.7 Check the rings with the level, correcting the attitude of the rings to be plumb and vertical, as needed.

NOTE 8—A shallower depth (<150 mm) may be used in cases where it is not possible to drive the ring to the 150 mm depth or excavate a trench to the 150 mm depth.

8.6 *Tamping Disturbed Soil:*

8.6.1 If the surface of the soil surrounding the wall of the ring(s) is excessively disturbed (signs of extensive cracking, excessive heave, and the like), reset the ring(s) using a technique that will minimize such disturbance.

8.6.2 If the surface of the soil surrounding the wall of the ring(s) is only slightly disturbed, tamp the disturbed soil adjacent to the inside and outside wall of the ring(s) until the soil is as firm as it was prior to disturbance.

8.7 *Maintaining Liquid Level:*

8.7.1 There are basically three ways to maintain a constant head (liquid level) within the inner ring and annular space between the two rings: manually controlling the flow of liquid, the use of constant-level float valves, or the use of a Mariotte bottle.

8.7.2 When manually controlling the flow of liquid, a depth gauge is required to assist the investigator visually in maintaining a constant head. Use a depth gauge such as a steel tape or rule for soils having a relatively high permeability; for soils having a relatively low permeability use a hook gauge or simple point gauge.

8.7.3 Install the depth gauges, constant-level valves, or Mariotte bottles as shown in Fig. 2, and in such a manner that the reference head will be at least 25 mm (1 in.) and not greater than 150 mm (6 in.). Select the head on the basis of the permeability of the soil, the higher heads being required for lower permeability soils. Locate the depth gauges near the center of the center ring and midway between the two rings.

8.7.4 Cover the soil surface within the center ring and between the two rings with splash guards (for example, 150-mm (6-in.) square pieces of burlap or rubber sheet) to prevent erosion of the soil when the initial liquid supply is poured into the rings.

8.7.5 Use a pail to fill both rings with liquid to the same desired depth in each ring. Do not record this initial volume of liquid. Remove the splash guards.

8.7.6 Start flow of fluid from the graduated cylinders or Mariotte bottles. As soon as the fluid level becomes basically constant, determine the fluid depth in the inner ring and in the

annular space to the nearest 2 mm (1/16 in.) using a ruler or tape measure. Record these depths. If the depths between the inner ring and annular space varies more than 5 mm (1/4 in.), raise the depth gauge, constant-level float valve, or Mariotte bottles having the shallowest depth to ensure similar fluid depth between the inner ring and the annular space.

8.7.7 Maintain the liquid level at the selected head in both the inner ring and annular space between rings as near as possible throughout the test, to prevent flow of fluid from one ring to the other.

NOTE 9—This most likely will require either a continuing adjustment of the flow control valve on the graduated cylinder, or the use of constant-level float valves. A rapid change in temperature may preclude use of the Mariotte bottle.

8.8 *Measurements:*

8.8.1 Record the ground temperature at a depth of about 300 mm (12 in.), or at the mid-depth of the test zone.

8.8.2 Determine and record the volume of liquid that is added to maintain a constant head in the inner ring and annular space during each timing interval by measuring the change in elevation of liquid level in the appropriate graduated cylinder or Mariotte bottle. Also, record the temperature of the liquid within the inner ring.

8.8.3 For average soils, record the volume of liquid used at intervals of 15 min for the first hour, 30 min for the second hour, and 60 min during the remainder of a period of at least 6 h, or until after a relatively constant rate is obtained.

8.8.4 The appropriate schedule of readings may be determined only through experience. For high-permeability materials, readings may be more frequent, while for low-permeability materials, the reading interval may be 24 h or more. In any event, the volume of liquid used in any one reading interval should not be less than approximately 25 cm³ (1.5 in.³).

8.8.5 Place the driving cap or some other covering over the rings during the intervals between liquid measurements to minimize evaporation (see 8.2.1).

8.8.6 Upon completion of the test, remove the rings from the soil, assisted by light hammering on the sides with a rubber hammer.

9. **Calculations**

9.1 Convert the volume of liquid used during each measured time interval into an incremental infiltration velocity for both the inner ring and annular space using the following equations:

9.1.1 For the inner ring calculate as follows:

$$V_{IR} = \Delta V_{IR} / (A_{IR} \cdot \Delta t) \tag{1}$$

where:

- V_{IR} = inner ring incremental infiltration velocity, cm/h,
- ΔV_{IR} = volume of liquid used during time interval to maintain constant head in the inner ring, cm³,
- A_{IR} = internal area of inner ring, cm², and
- Δt = time interval, h.

9.1.2 For the annular space between rings calculate as follows:

$$V_A = \Delta V_A / (A_A \cdot \Delta t) \tag{2}$$

where:

- V_A = annular space incremental infiltration velocity, cm/h,
- ΔV_A = volume of liquid used during time interval to maintain constant head in the annular space between the rings, cm^3 , and
- A_A = area of annular space between the rings, cm^2 .

10. Report: Test Data Sheet(s)/Form(s)

10.1 Record as a minimum the following general information (data):

- 10.1.1 Location of test site.
- 10.1.2 Dates of test, start and finish.
- 10.1.3 Weather conditions, start to finish.
- 10.1.4 Description of test site, including boring profile.
- 10.1.5 Name(s) of technician(s).

10.2 Record as a minimum the following test data:

- 10.2.1 Type of liquid used in the test. If available, a full analysis of the liquid including pH also should be recorded.
- 10.2.2 Areas of rings and the annular space between rings (nearest 1 cm^2 or better).
- 10.2.3 Volume constants for graduated cylinders or Mariotte bottles (nearest 0.01 cm^3 or better).
- 10.2.4 Depth of liquid in inner ring and annular space (nearest 2 mm or better).
- 10.2.5 Record of ground and liquid temperatures (nearest 0.5°C), incremental volume measurements (nearest 1 cm^3 or better), and elapsed time (nearest 1 min. or better).

10.2.6 Incremental infiltration velocities (use 3 significant digits) for inner ring and annular space. The rate of the inner ring should be the value used if the rates for inner ring and annular space differ.

10.2.7 If available, depth to the water table and a description of the soils found between the rings and the water table, or to a depth of about 1 m (3 ft).

10.2.8 A plot of the incremental infiltration rate versus total elapsed time.

10.3 An example field records form is given in Fig. 3.

10.4 See Appendix X1 for information on the determination of the moisture pattern.

11. Precision and Bias

11.1 No statement on precision and bias can be made due to the variability in soils tested and in the types of liquids that might be used in this test method. Because of the many factors related to the soils, as well as the liquids that may affect the results, the recorded infiltration rate should be considered only as an index value.

12. Keywords

12.1 coefficient of permeability; hydraulic conductivity; infiltration rate; infiltrometer; in-situ testing; Mariotte bottle

APPENDIX

(Nonmandatory Information)

X1. DETERMINATION OF MOISTURE PATTERN

X1.1 Although not considered a required part of the test method, the determination of the moisture pattern in the moistened soil beneath the infiltration rings commonly provides information useful in interpreting the movement of liquid through the soil profile. For example, horizontal liquid movement may be caused by lower-permeability layers and will be identified by a lateral spreading of the wetted zone. Thus, the exploration of the soil moisture pattern below an infiltration test in an unfamiliar area may identify subsurface conditions that may have affected the test and later applications of the data.

X1.2 If the investigator wishes to make such a study, dig a trench so that one wall of the trench passes along the center line

of the former position of the rings. Orient the trench so that the other wall is illuminated by the sun, if the day is sunny. If feasible, dig the trench large enough to include all of the newly moistened area. Collect samples from the shaded wall of the trench for determination of water content. If preferred, an auger, such as the orchard barrel type, may be used to determine the approximate outline of the moistened area below the rings and to collect samples for water content.

X1.3 Plot the visibly moistened area on graph paper or on the cross-section part of the report form. If samples were collected and water contents were determined, contours of water content also can be plotted on the graph.

SUMMARY OF CHANGES

Committee D18 has identified the location of selected changes to this standard since the last issue (2009) that may impact the use of this standard. (March 1, 2018)

- | | |
|--|---|
| (1) Removed the use of chain saws from the standard. | (3) Improved the figures. |
| (2) Improved the discussion on the placement of bentonite grout in the trenches for the rings. | (4) Added missing details to the text. |
| | (5) Changed Mariotte tube to Mariotte bottle. |

ASTM International takes no position respecting the validity of any patent rights asserted in connection with any item mentioned in this standard. Users of this standard are expressly advised that determination of the validity of any such patent rights, and the risk of infringement of such rights, are entirely their own responsibility.

This standard is subject to revision at any time by the responsible technical committee and must be reviewed every five years and if not revised, either reapproved or withdrawn. Your comments are invited either for revision of this standard or for additional standards and should be addressed to ASTM International Headquarters. Your comments will receive careful consideration at a meeting of the responsible technical committee, which you may attend. If you feel that your comments have not received a fair hearing you should make your views known to the ASTM Committee on Standards, at the address shown below.

This standard is copyrighted by ASTM International, 100 Barr Harbor Drive, PO Box C700, West Conshohocken, PA 19428-2959, United States. Individual reprints (single or multiple copies) of this standard may be obtained by contacting ASTM at the above address or at 610-832-9585 (phone), 610-832-9555 (fax), or service@astm.org (e-mail); or through the ASTM website (www.astm.org). Permission rights to photocopy the standard may also be secured from the Copyright Clearance Center, 222 Rosewood Drive, Danvers, MA 01923, Tel: (978) 646-2600; <http://www.copyright.com/>

ATTACHMENT 3
Water Infiltration Test Field Forms

